

**Engineering solutions and industrial  
applications, leader in Industry 4.0**



## Over 75 years of history

For over 75 years now Elprom Trojan plant has been a leader in Central and Eastern Europe in the field of electric motors manufacturing. We have been defined as the giant on the Balkans. Founded in 1945 in the town of Trojan, in the years following 1947, the plant became structure-determinant for Bulgaria, delivering supply mainly for the countries of Western Europe and Northern Africa and at the same time expanding in terms of presence in the rest of the world.

Elprom Trojan has been selling its products in Europe, Asia, Africa, South and North America, reaching the amount of 72 000 electric motors per month. Six generations of engineers have had merit and distribution to this achievement as through their experience they have contributed in building up and implementation of the international standards in the particular industry throughout the years. Thus, the electric motors construction and manufacturing has become a tradition for Trojan and has transformed itself into quality criteria.

Today Elprom Trojan could be proud of the fact that for its 75 years of history it has manufactured and sold over 27 000 000 electric motors in 123 countries all over the world.

In 1981 Elprom Trojan was awarded with the prestigious Golden Mercury award, for production, development and international cooperation.

Therefore, we can say **WE ARE EVERYWHERE** and for 75 years now we have worked for all of you and this is something we are really proud of.

## Eine über 75 Jahre alte Geschichte

Schon 75 Jahre ist das Unternehmen Elprom Trojan Führer in der Herstellung von Elektromotoren im Mittel- und Osteuropa. Es ist als der Gigant auf der Balkanhalbinsel bestimmt. Das Unternehmen wurde 1945 in Trojan gegründet. In den Jahren nach 1947 wurde die Herstellung strukturellbestimmend für Volksrepublik Bulgarien, in dem das Unternehmen vorwiegend Lieferungen für Länder aus Westeuropa und Nordafrika sichert, aber die Lieferungen verbreiten sich auch auf den anderen Teilen der Welt.

Elprom Trojan verkauft in Europa, Asien, Afrika, Süd- und Nordamerika, in dem es einen Umfang von 72 000 Elektromotoren pro Monat erreicht. Verdienst und Beitrag dazu haben schon 6 Generationen Ingenieure, die mit ihrer Erfahrung zum Aufbau und Einführung der internationalen Standarte in dieser Industrie in den Jahren beitragen. So wurde das Konstruieren und die Herstellung von Elektromotoren eine Tradition für Trojan und wurde ein Kriterium für Qualität.

Heute kann Elprom Trojan mit Stolz sagen, dass er für seine über 75 Jahre alte Geschichte über 27 000 000 Elektromotoren hergestellt und in über 123 Ländern auf der Welt verkauft hat.

Im Jahre 1981 ist Elprom Trojan mit dem internationalen Prestigepreis Der goldene Merkur für Entwicklung der Herstellung und der internationalen Zusammenarbeit ausgezeichnet.

Deshalb können wir sagen, dass **WIR ÜBERALL SIND**, und dass wir schon über 75 Jahre für Sie alle arbeiten, etwas worauf wir stolz sind.

## We are everywhere

The production of Elprom Trojan is in compliance with Regulation /EU/ No640/2009 of the Commission for implementing Directive 2005/32/EC of the European Parliament and of the European Council with regard to eco-design requirements for the electric motors. European Union has introduced particular laws on the matter with the objective of reducing energy consumption and so CO2 emissions. EU Directive 640/2009 refers to energy consumption or efficiency of induction motors in the industrial environment. The latter act is now effective throughout every country in the European economic area, as well as in Bulgaria.

Since the establishment of the company more than 21 series of electric motors have been developed and introduced in plant's production. In addition, there are hundreds of non-standard electric motor types meeting specific requirements.

## Wir sind überall

Die Produktion von Elprom Trojan ist in Übereinstimmung mit der Dienstvorschrift /EO/ No640/2009 der Kommission für Anlegen der Direktive 2005/32/EO des Europäischen Parlaments und des Europarats hinsichtlich der Anforderungen für Ökodesign der Elektromotoren. Die Gesetze sind in der EU eingeführt, mit dem Ziel Verminderung des Elektroenergieverbrauchs und infolgedessen der Kohlenstoffemissionen CO2. Die europäische Direktive bezieht sich auf Energieverbrauch oder auf die Effektivität der Asynchronelektromotoren in der Industrieumgebung. Diese Direktive ist in Kraft in jedem Land der europäischen Wirtschaftszone, sowie auch in Bulgarien.

Seit der Gründung des Unternehmens bis jetzt sind ausgearbeitet und in Herstellung über 21 Serien von Elektromotoren eingeführt. Tausende sind die Elektromotoren mit spezifischen Forderungen.

## Content

## Inhalt

1. General technical data	4	1. Allgemeine technische Angaben	4
2. Three-phase asynchronous electric motors with squirrel-cage rotor, series T-IE1, TH-IE2	8	2. Drehestorm-Asynchronmotoren mit Käfigläufer, Serie T-IE1, TH-IE2	8
3. Three-phase asynchronous electric motors with squirrel-cage rotor, series TP-IE3	16	3. Drehestorm-Asynchronmotoren mit Käfigläufer, Serie TP-IE3	16
4. Three-phase asynchronous electric motors with brake, series T-BR-IE1	20	4. Drehestorm-Asynchronmotoren mit Bremse, Serie T-BR-IE1	20
5. Three-phase asynchronous electric motors with brake, series T-BR-B5-IE 1	26	5. Drehestorm-Asynchronmotoren mit Bremse, Serie T-BR-B5-IE 1	26
6. Three-phase asynchronous electric motors with brake, series T-42-IE 1	30	6. Drehestorm-Asynchronmotoren mit Bremse, Serie T-42-IE 1	30
7. Three-phase asynchronous electric motors with brake, series KT-IE 1	32	7. Drehestorm-Asynchronmotoren mit Bremse, Serie KT-IE 1	32
8. Three-phase asynchronous electric motors with brake, series KT-35-IE 1	34	8. Drehestorm-Asynchronmotoren mit Bremse, Serie KT-35-IE 1	34
9. Three-phase asynchronous electric motors with brake, series KT-53-IE 1	36	9. Drehestorm-Asynchronmotoren mit Bremse, Serie KT-53-IE 1	36
10. Three-phase asynchronous electric motors with brake, series CT-K-IE 1	38	10. Drehestorm-Asynchronmotoren mit Bremse, Serie CT-K-IE 1	38
11. Three-phase asynchronous electric motors with brake, series CT-240;290;360-IE 1	40	11. Drehestorm-Asynchronmotoren mit Bremse, Serie CT-240;290;360-IE 1	40
12. Single-phase asynchronous electric motors with squirrel-cage rotor and running capacitor, series ER	42	12. Einphasen-Asynchronmotoren mit Käfigläufer, mit Betriebskondensator, Serie ER	42
13. Single-phase induction electric motors with squirrel-cage rotor and with high starting torque, series ERR	44	13. Einphasen-Asynchronmotoren mit Käfigläufer, mit betriebskondensator, mit erhöhtem Anlaufmoment, Serie ERR	44
14. Single-phase induction electric motors with squirrel-cage rotor, starting and running capacitor, series ESR	48	14. Einphasen-Asynchronmotoren mit Kurzschlussläufer, mit Anlass- und Betriebskondensator, Serie ESR	48
15. Spare parts	52	15. Ersatzteile	52
16. History of the plant	72	16. Geschichte	72

## GENERAL TECHNICAL DATE

## ALLGEMEINE ANGABEN

### NORMS AND INSTRUCTIONS

All motors meet requirements  
of the below mentioned standards and norms:

### NORMEN UND VORSCHRIFTEN

Alle Motoren entsprechen  
den folgenden Normen und Vorschriften

TITLE TITEL	INTERNATIONAL IEC	EU GENELEC
Electrical rotating machines / rated operation and characteristic data Allgemeine Bestimmungen für umlaufende elektrische Maschinen Oberflächengekühlte Käfigläufermotoren	IEC 634-1	EN 60034-1
Methods for determining losses and efficiency of rotating electrical machines Standardverfahren zur Bestimmung der Verluste und des Wirkungsgrades aus Prüfungen	IEC 634-2	EN 60034-2
Protection types rotating electrical machines Schutzarten umlaufender elektrischer Maschinen	IEC 634-5	EN 60034-5
Cooling methods of rotating electrical machines Kühlarten umlaufender elektrischer Maschinen	IEC 634-6	EN 60034-6
Construction types of rotating electrical machines Bauformen umlaufender elektrischer Maschinen	IEC 634-7	EN 60034-7
Terminal markings and direction of rotating electrical machines Anschlußbezeichnungen und Drehsinn für elektrischer Maschinen	IEC 634-8	EN 60034-8
Noise emission, limit values Geräuschemission, Grenzwerte	IEC 634-9	EN 60034-9
Restart characteristics for rotating electrical machines Anlaufverhalten von Drehstrom - Käfigläufermotoren	IEC 634-12	EN 60034-12
Vibration severity of rotating electrical machines Messung, bewertung und Grenzwerte der Schwingstärke	IEC 634-14	EN 60034-14
Asynchronous AC motors for general use with standartized dimensions and outputs Drehstromasynchronmotoren für den Allgemeingebrauch mit standardidierten Abmessungen und Leistungen	IEC 6672 fixed only	EN 60072

## Harmonization of the efficiency classes

Different energy efficiency standards exist worldwide for induction motors. To promote international harmonization, the international standard IEC 60034-30:2008 (Rotating electrical machines-Part 30:Efficiency classes of single-speed, three-phase, cage-induction motors(IE code)) was created. This group low-voltage asynchronous motors into new efficiency classes (valid since October 2008). The efficiencies of IEC 60034-30:2008 are based on losses determined in accordance with the IEC 60034-2-1:2007 standard.

This has been valid since November 2007 and replaces the IEC 60034-2:1996 standard as of November 2010.

The supplementary losses are now measured and no longer added as a percentage.

### IE efficiency classes

The efficiency classes are groups according to the following nomenclature (IE = International Efficiency):

**IE1** - Standard Efficiency

**IE2** - High Efficiency

**IE3** - Premium Efficiency

**IE4** - Super Premium Efficiency

In the standard, the normal 50Hz limits of Standard (IE1) and High Efficiency(IE2) are based on the CEMER-EU EFF2 and EFF1 limits respectively. However, they have been adjusted to take the different test procedures into account (CEMER: Additional load losses PLL are 0.5% of input power; in this standard PLL is determined from test).

### Common information

Comprehensive laws have been introduced in the European Union with the objective of reducing energy consumption and therefore CO<sub>2</sub> emission. EU Directive 640/2009 concerns the energy consumption of efficiency of induction motors in the industrial environment. This Directive is now in force in every country of the European economic area, as in Bulgaria.

## Anpassung der Effektivitätsklassen

Für die Induktionsmotoren gibt es global verschiedene Standarde für Energieeffektivität. Um zur internationalen Koordination beigetragen zu werden, wurde ein internationaler Standard IEC 60034-30:2008 geschaffen (Rotationselektromaschinen - Teil 30: es sind Effektivitätsklassen von eingängigen Asynchronelektromotoren mit kurz verbundenem Rotor (IE - Kode geschaffen). Diese Gruppe Niedervolt-Asynchronelektromotoren ist mit neuen Effektivitätsklassen (gültig seit Oktober 2008). Die Effektivität von IEC 60034-30:2008 stützt sich auf Verluste, die dem Maß des Standards IEC 60034-2-1:2007 bestimmt sind.

Das ist seit November 2007 gültig und seit November 2010 ersetzt Standard IEC 60034-2:1996.

Die zusätzlichen Verluste werden jetzt gemessen und sie werden nicht als Prozent hinzugehen.

### IE Effektivitätsklassen

Die Effektivitätsklassen sind nach der folgenden Nomenklatur gruppiert (IE = Internationale Effektivität)

**IE1** - Standardeffektivität

**IE2** - Hohe Effektivität

**IE3** - Premium Effektivität

**IE4** – Super Premium Effektivität

In diesem Standard beruhen die Toleranzen der Nominellparameter bei 50 Hz für Standard (IE1) und hohe Effektivität (IE2) entsprechend auf CEMER-EU EFF2 und EFF1. Sie sind trotzdem korrigiert, um die verschiedenen Verfahren für Probe zu beachten (CEMER: zusätzliche Verluste der Belastung PLL sind 0.5% von der Nennleistung, in diesem Standard wird PLL von der Probe bestimmt).

### Allgemeine information









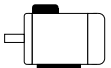

In der EU sind Gesetze eingeführt, mit dem Ziel Verminderung des Elektroenergieverbrauchs und infolgedessen der Kohlenstoffemissionen (CO<sub>2</sub>). Die europäische Direktive bezieht sich auf Energieverbrauch oder auf die Effektivität der Asynchronelektromotoren in der industrienumgebung. Die vorliegende Direktive ist in Kraft in jedem Land des europäischen Wirtschaftsraums, sowie auch in Bulgarien.

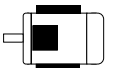
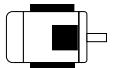
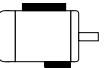
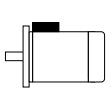
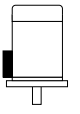
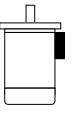
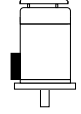
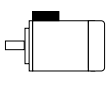
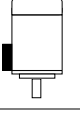
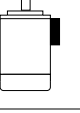
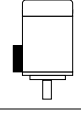
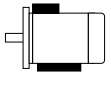
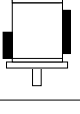
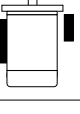
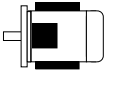
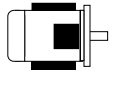
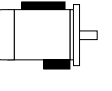
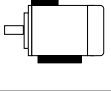
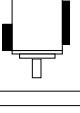
## TYPE OF EXECUTIONS

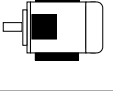
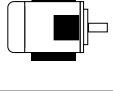
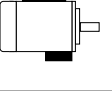
## BAUFORMEN

The electric motors are produced in shown types of execution and ways of assembly. The dimensions of the basic types IM B3, IM B5 and IM B14 are shown in the respective applications. The combinations between IM B3 and IM B5 and IM B14 do not change the joining dimensions.

Die Motoren werden in den angegebenen Bauformen ausgeführt. Die Abmessungen der Grundbauformen IM B3, IM B5 und IM B14 sind in den entsprechenden Anhängen angegeben. Die Kombinationen von IM B3 mit IM B5 und IM B14 ändern nicht die Anbaumaße.

<b>Efficiency classes</b> <b>IE1, IE2, IE3</b>	<b>IM B3</b> <b>IM 1001</b> 	<b>IM V5</b> <b>IM 1011</b> 	<b>IM V6</b> <b>IM 1031</b> 	<b>IM B6</b> <b>IM 1051</b> 	<b>IM B8</b> <b>IM 1071</b> 	<b>IM B7</b> <b>IM 1061</b> 	<b>Frame sizes</b> <b>63-160</b>
<b>Efficiency classes</b> <b>IE1, IE2, IE3</b>	<b>IM B5</b> <b>IM 3001</b> 	<b>IM V1</b> <b>IM 3011</b> 	<b>IM V3</b> <b>IM 3031</b> 	<b>IM V1 with canopy</b> <b>IM 3011</b> 			<b>Frame sizes</b> <b>63-160</b>
<b>Efficiency classes</b> <b>IE1, IE2, IE3</b>	<b>IM B14</b> <b>IM 3601</b> 	<b>IM V18</b> <b>IM 3611</b> 	<b>IM V19</b> <b>IM 3631</b> 	<b>IM V18 with canopy</b> <b>IM 3611</b> 			<b>Frame sizes</b> <b>63-160</b>
<b>Efficiency classes</b> <b>IE1, IE2, IE3</b>	<b>IM B35</b> <b>IM 2001</b> 	<b>IM V15</b> <b>IM 2011</b> 	<b>IM V36</b> <b>IM 2031</b> 	<b>IM 2051</b> 	<b>IM 2061</b> 	<b>IM 2071</b> 	<b>Frame sizes</b> <b>63-160</b>
<b>Efficiency classes</b> <b>IE1, IE2, IE3</b>	<b>IM B34</b> <b>IM 2101</b> 	<b>IM V15</b> <b>IM 2111</b> 	<b>IM V36</b> <b>IM 2131</b> 	<b>IM 2151</b> 	<b>IM 2161</b> 	<b>IM 2171</b> 	<b>Frame sizes</b> <b>63-160</b>
<b>Efficiency classes</b> <b>IE1, IE2, IE3</b>	<b>IM 1002</b> 	<b>IM 1012</b> 	<b>IM 1032</b> 	<b>IM 1052</b> 	<b>IM 1062</b> 	<b>IM 1072</b> 	<b>Frame sizes</b> <b>63-160</b>

## BEARING

## LAGER

All motors are produced with single-row ball bearings, enclosed at both sides and lowered level of vibrations. The designation of type is according to Table 1. The motors can be executed with other types of bearings on request.

Alle Motoren werden mit beidseitig geschlossenen Einreihen-Kugellager mit niedrigem Schwingungspegel ausgeführt. Die Typenbezeichnung ist gem. Tabelle 1. Nach Anfrage sind Lieferungen mit anderen Lagertypen möglich.

Table 1

Tabelle 1

Size	Type	Front bearing	Rear bearing
Baugröße	Typ	AS - Lager	BS - Lager
63	T, ER	6201-2Z	6201-2Z
71	T, ER	6202-2Z	6202-2Z
80	T, TH, TP, ER, ERR, ESR	6204-2Z, C3	6204-2Z, C3
90	T, TH, TP, ER, ERR, ESR	6205-2Z, C3	6205-2Z, C3
100	T, TH, TP, ESR	6206-2Z, C3	6206-2Z, C3
112	T, TH, TP	6206-2Z, C3	6206-2Z, C3
132	T, TH, TP	6308-2Z, C3	6308-2Z, C3
160	T, TH, TP	6309-2Z, C3	6309-2Z, C3

## DRIVING SHAFT END

## ARBEITSWELLENENDE

Normally the motors are produced with cylindrical shaft end without internal thread. On request and additional payment the motors can be executed with internal thread and centre taper according to the shaft diameter are shown in Table 2. Other execution of the driving shaft end and other types of thread is possible on request.

Die Motoren werden mit zylindrischem Arbeitswellenende ohne Innengewinde ausgeführt. Nach Anfrage und gegen Mehrpreis können die Motoren mit Innengewinde und Zentrierbohrungen nach DIN 332, Blatt 1 und 2, Form A geliefert werden. Die Gewindemaße gem. dem Wellendurchmesser sind in der Tabelle 2 angegeben. Nach Anfrage sind auch eine andere Arbeitswellenausführung und andere Gewinderaten möglich.

All motors are dynamically balanced as well as the key with which they are delivered.

Alle Läufer sind dynamisch mit eingelegter Passfeder ausgewuchtet, mit der sie komplett geliefert werden.

On request the motors can be executed with a second driving shaft end.

Nach Anfrage können die Motoren mit zweitem Arbeitswellenende geliefert werden.

Table 2

Tabelle 2

Dimensions of the driving end of the shaft, mm	Tread, mm	Arbeitswellenendendurchmesser, mm	Gewinde, mm
above 10 up to 13	M4 x 10	über 10 bis 13	M4 x 10
above 13 up to 16	M5 x 12.5	über 13 bis 16	M5 x 12.5
above 16 up to 21	M6 x 16	über 16 bis 21	M6 x 16
above 21 up to 24	M8 x 19	über 21 bis 24	M8 x 19
above 24 up to 30	M10 x 22	über 24 bis 30	M10 x 22
above 30 up to 38	M12 x 28	über 30 bis 38	M12 x 28
above 38 up to 42	M16 x 36	über 38 bis 42	M16 x 36

## Three-phase electric motors

**Axis height of rotation in mm** - 63, 71,80, 90,100, 112, 132, 160;

**Power supply** - 0. 120 kW up to 15 kW depending on the poles;

**Pole: IE1** - 2, 4, 6, 8, 12, 4/2,8/4, 8/2, 12/4; **IE2, IE3** - 2, 4, 6;

**Synchronous revolutions min<sup>-1</sup>: IE1** - 3000, 1500, 1000, 750, 500, 1500/3000, 750/1500, 750/3000, 500/1500;

**Synchronous revolutions min<sup>-1</sup>: IE2, IE3** - 3000, 1500, 1000;

**Rated voltage and frequency** - 127 V up to 400 V at Δ connection, and 220 V up to 690 V at Y connection;

**Frequency** - 50 Hz and 60 Hz;

**Duty cycle** - S1, S2, S3, S4, S6;

**Types of mounting** - B3, B5, B14, B3/B5(B35), B3/B14(B34);

The adjusted flange can be of special type, as per customer's request.

**Driving shaft end** - Cylindrical with key, with or without inner thread, with two driving ends, as well as other varieties. Degree of protection - IP54, IP55;

**Class of insulation** - standard F, could be also H - as per request;

**Operating conditions** - moderate climate zone "n" at temperature -25° C up to +40° C;

**Attitude** - 1000 m;

**Ambient temperature** - standard of -25° C up to +40° C;

having a special mounting type, it is possible to be -40° C up to +50° C.

### Power

The rated power of the shaft is defined under the following conditions:

Rated voltage, pointed on the plate at tolerance ±10%;

Frequency of the supply voltage at tolerance ±1%;

**Ambient temperature** - -25° C up to +40° C;

**Altitude** - up to 1000 m;

**Duty cycle S1** - continuous, EN 60034-1;

At deviation of the indicated conditions, the admissible power of the shafts is defined by formula:

$$P_d = K_t \cdot K_h \cdot P_n$$

where:

**P<sub>d</sub>** - is the admissible power of shaft

**K<sub>t</sub>** - is the corrective coefficient, pointing the influence of the ambient temperature

**K<sub>h</sub>** - is the corrective coefficient, pointing the influence of the altitude

**P<sub>n</sub>** - is the rated power, pointed on the plate

See table 1 and 2 for the corrective coefficients

Table 1: Corrective coefficient, pointing the influence of the ambient temperature

t° [°C]	40	45	50	55	60
K <sub>t</sub> [-]	1	0.95	0.90	0.83	0.78

Table 2: Corrective coefficient, pointing the influence of the altitude

h[m]	1000	1500	2000	2500	3000	4000
K <sub>h</sub> [-]	1	0.98	0.95	0.91	0.87	0.78

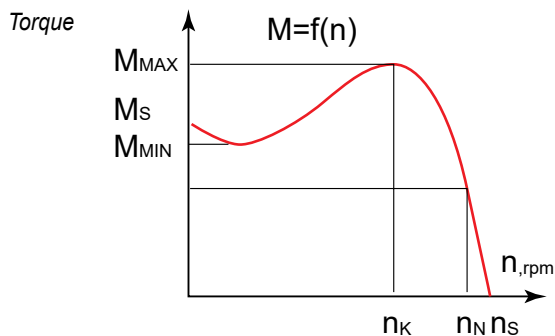

The rated torque at the output end of the electric motor is calculated by the dependence of

$$M = (9,55 \cdot P) / n$$

where

**M** [N.m] - rated torque

**P** [W] - rated power

**n** [min<sup>-1</sup>] - rated rotation speed

**M<sub>s</sub>** - starting torque

**M<sub>min</sub>** - minimum torque

**M<sub>max</sub>** - maximum torque

## Three-phase asynchronous electric motors with brake motors

The three-phase electric motors with electromagnetic brake are used for built-in machineries and devices where faster brake and positioning is needed.

The brake is electromagnetic, with DC voltage supply, non-adjustable.

The electric motors can be manufactured with independent cooling.

The three-phase electric motors with electromagnetic brake are manufactured with height of the axis rotation from 63 mm up to 160 mm.

### Braking:

**Slow braking** - when slow braking is activated, the AC supply of the brake is disconnected simultaneously with that of the electric motor.

**Fast braking** - when slow braking is activated, the AC supply of the brake is disconnected simultaneously with the AC supply of the electric motor.

## Dreiphasenasynchronmotoren

**Drehachshöhe in mm** - 63, 71,80, 90,100, 112, 132, 160;

**Leistung** - von 0.120 kW bis 15 kW in Abhängigkeit von den Polen;

**Polen: IE1** - 2, 4, 6, 8, 12, 4/2,8/4, 8/2, 12/4; **IE2, IE3** - 2, 4, 6;

**Synchrone Drehzahl min<sup>-1</sup>: IE1** - 3000, 1500, 1000, 750, 500, 1500/3000, 750/1500, 750/3000, 500/1500;

**Synchrone Drehzahl min<sup>-1</sup>: IE2, IE3** - 3000, 1500, 1000;

**Nennspannung und Frequenz** - von 127V bis 400V bei Verbindung in  $\Delta$  und von 220V bis 690 V bei Verbindung in Y, und Frequenz 50 Hz and 60 Hz;

**Betrieb** - S1, S2, S3, S4, S6;

**Bauformen** - B3, B5, B14, B3/B5(B35), B3/B14(B34);

**Nach Wunsch des Kunden kann der Vereinigungsflansch speziell sein Arbeitswellenende** - zylindrisch mit Passfeder, ohne oder mit Innengewinde, spwziel, verzahnt, profiliert mit zwei Arbeitsenden, sowie andere Variationen;

**Schutzart** - IP54, IP55;

**Isolierstoffklasse** - standart F, nach Anfrage kann auch H sein Betriebsbedingungen - gemäßigtes Klimagebiet "n" bei Temperaturen von -25° C up to +40° C und Aufstellungshöhe bis 1000 m über NN

**Umwelttemperatur** - genormt von -25° C up to +40° C, bei speziellen Ausführungen kann bis -40° C oder bis +50° C sein.

### Leistung

Die Nennleistung der motorwelle wird bei den folgenden Bedingungen bestimmt: Nennspannung, gezeigt auf der Tabelle bei Toleranz  $\pm 10\%$ ;

Frequenze der Speisespannung bei Toleranz  $\pm 1\%$ ;

**Umwelttemperatur** - von -25° C bis +40° C;

**Meershöhe** bis 1000 m;

**Betrieb** - S1 dauernd EN 60034-1;

Bei Abweichungen von den angegebenen Bedingungen wird die zulässige Spannung der Motorwelle nach der Formel bestimmt:

$$P_d = K_t \cdot K_h \cdot P_n$$

wo:

**P<sub>d</sub>** - die zulässige Spannung der Motorwelle

**K<sub>t</sub>** - Korrekturkoeffizient, der den Einfluss der Umwelttemperatur abliest

**K<sub>h</sub>** - Korrekturkoeffizient, der den Einfluss der Meereshöhe abliest

**P<sub>n</sub>** - Nennleistung der Motorwelle, bezeichnet auf der tabelle

Die Korrekturkoeffizienten werden von Tabellen 1 und 2 abgelesen

Tabelle 1: Korrekturkoeffizient, der den Einfluss der Umwelttemperatur abliest

t° [°C]	40	45	50	55	60
K <sub>t</sub> [-]	1	0.95	0.90	0.83	0.78

Tabelle 2: Korrekturkoeffizient, der den Einfluss der Meereshöhe abliest

h[m]	1000	1500	2000	2500	3000	4000
K <sub>h</sub> [-]	1	0.98	0.95	0.91	0.87	0.78

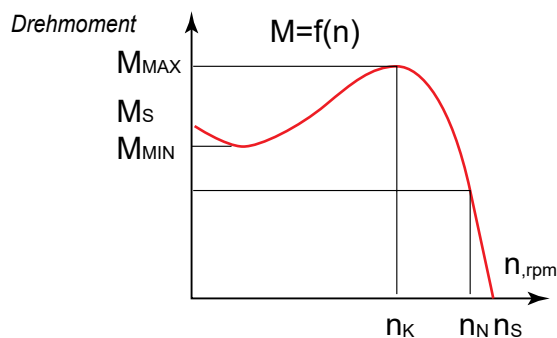

Der Nenndrehmoment am Ausgangsendes des Elektromotors wird nach der Formel gerechnet

$$M = (9,55 \cdot P) / n$$

wo

$M$  [N.m] - Nenndrehmoment

$P$  [W] - Nennspannung

$n$  [min<sup>-1</sup>] - Nenngeschwindigkeit der Drehung

$M_s$  - Anlaufmoment

$M_{min}$  - Minimalmoment

$M_{max}$  - Höchstmoment

## Dreiphasen - Asynchronelektromotoren mit allgemeiner Bestimmung mit Bremse

Dreiphasen - Asynchronelektromotoren mit Elektromagnetbremsen benutzt man für Einbau in Maschinen und Mechanismen, wo es eine schnellere Bremsung und Positionieren notwendig ist.

Die Bremse der Motoren ist Elektromagnet, mit Gleichstrom, nicht regelbar.

Die Motoren können auch mit unabhängiger Kühlung ausgeführt werden.

Die dreiphasen - Asynchronelektromotoren mit Elektromagnetbremsen werden mit einer Drehachshöhe von 63 mm bis 160 mm aus geführt.

### Bremsung:

**Verlangsamte Bremsung** - bei verlangsamer Bremsung wird die stromvariable Speisung der Bremse gleichzeitig mit der des Elektromotors unterbrochen.

**Schnelle Bremsung** - bei schneller Bremsung wird die Gleichstromspeisung der Bremse gleichzeitig mit Wechselstromspeisung des Elektromotors unterbrochen.

Rated Output		Type	Parameters at Rated Output				Starting characteristics			Torque of Inertia	Weight	
			Rotation speed	Current	Efficiency	Power Factor	Current	Torque			Cast Iron	All alloy
P <sub>2</sub>	Indication	n	I <sub>R</sub>	η	cosφ	I <sub>S</sub> /I <sub>R</sub>		M <sub>S</sub> /M <sub>R</sub>	M <sub>MAX</sub> /M <sub>R</sub>	J		
kW	HP	rpm	A	%					kg.m <sup>2</sup>	kg		

3000 rpm

0.18	0.25	T63A-2	2770	0.49	64	0.81	2.9	2.10	2.4	0.000141	-	3.8
0.25	0.34	T63B-2	2770	0.67	69	0.78	4.1	2.25	2.5	0.000188	-	4.2
0.37	0.50	T71A-2	2800	0.91	71	0.83	4.3	2.20	2.4	0.000333	-	5.4
0.55	0.75	T71B-2	2790	1.33	71	0.81	4.1	2.30	2.4	0.000352	-	5.7
0.75	1.00	T71C-2	2740	1.90	70	0.84	3.7	2.20	2.4	0.000410	-	6.5
0.75	1.00	T80A-2	2820	1.90	72	0.82	5.0	2.40	2.6	0.000900	-	8.2
1.10	1.50	T80B-2	2820	2.55	77	0.81	5.3	2.60	2.6	0.001000	-	9.3
1.50	2.00	T80C-2	2780	3.40	76	0.85	4.9	2.50	2.6	0.001100	-	11.3
1.50	2.00	T90S-2	2875	3.30	77	0.80	2.7	2.77	3.0	0.001630	18.5	12.8
2.20	3.00	T90L-2	2860	4.80	80	0.85	6.8	3.10	3.2	0.001820	22.0	16.3
3.00	4.00	T90LB-2	2810	6.10	88	0.88	6.0	2.60	2.8	0.002220	23.0	17.8
3.00	4.00	T100L-2	2880	6.20	82	0.87	7.2	2.50	2.7	0.003720	27.5	20.0
4.00	5.50	T100LB-2	2860	7.90	84	0.87	7.8	2.90	3.1	0.004560	29.5	22.0
4.00	5.50	T112M-2	2870	8.20	83	0.88	7.2	2.70	3.0	0.005830	36.0	26.2
5.50	7.50	T112MB-2	2870	11.40	83	0.86	7.2	2.80	3.0	0.007380	40.0	27.9
5.50	7.50	T132SA-2	2900	11.20	85	0.87	6.0	2.30	3.1	0.011500	50.0	34.4
7.50	10.20	T132SB-2	2905	14.30	85	0.89	7.0	2.10	2.8	0.014200	56.0	40.4
9.20	12.50	T132MA-2	2890	18.00	84	0.88	7.5	2.50	3.2	0.015800	66.0	59.7
11.00	15.00	T132M-2	2890	21.00	88	0.90	7.8	3.30	3.3	0.018180	68.0	62.5
11.00	15.00	T160MA-2	2910	20.30	88	0.90	6.0	2.00	2.5	0.026790	-	98.0
15.00	20.40	T160MB-2	2915	27.00	89	0.90	7.2	2.40	2.9	0.037000	-	111.0
18.50	25.20	T160 L-2	2910	32.60	90	0.92	7.2	2.40	3.0	0.045930	-	130.0

1500 rpm

0.12	0.16	T63A-4	1340	0.42	59	0.70	3.0	2.00	2.1	0.000177	-	3.7
0.18	0.25	T63B-4	1320	0.58	62	0.72	3.0	2.00	2.0	0.000231	-	4.1
0.25	0.34	T63C-4	1380	0.82	63	0.68	3.2	2.10	2.2	0.000318	-	5.1
0.25	0.34	T71A-4	1350	0.79	65	0.70	3.1	2.00	2.1	0.000590	-	5.2
0.37	0.50	T71B-4	1360	1.12	66	0.72	3.2	2.10	2.2	0.000720	-	6.1
0.55	0.75	T71C-4	1360	1.75	69	0.56	3.5	2.20	2.3	0.000900	-	7.3
0.55	0.75	T80A-4	1400	1.62	69	0.74	3.7	1.80	2.2	0.001280	-	8.4
0.75	1.00	T80B-4	1400	2.20	71	0.70	4.4	2.20	2.5	0.001540	-	9.2
1.10	1.50	T80C-4	1385	2.96	71	0.76	4.0	2.10	2.4	0.001980	-	10.3
1.10	1.50	T90S-4	1410	2.80	75	0.78	4.6	2.20	2.4	0.002550	18.0	12.7
1.50	2.00	T90L-4	1400	3.65	76	0.80	4.8	2.20	2.6	0.002780	21.0	15.3
2.20	3.00	T90LC-4	1400	5.30	75	0.80	5.5	2.50	2.7	0.003700	22.5	17.0
2.20	3.00	T100LA-4	1410	5.10	79	0.82	5.6	2.20	2.6	0.005030	27.0	19.5
3.00	4.00	T100LB-4	1410	6.80	81	0.82	5.8	2.70	2.8	0.006190	31.0	23.5
4.00	5.50	T100LC-4	1400	8.90	80	0.81	5.8	2.80	2.9	0.007820	34.5	37.5
4.00	5.50	T112M-4	1420	8.70	82	0.83	6.0	2.70	2.9	0.010900	38.5	38.7
5.50	7.50	T112MB-4	1400	11.50	83	0.83	6.3	2.80	3.1	0.014000	43.0	31.0
5.50	7.50	T132S-4	1440	11.50	85	0.83	6.2	2.60	2.8	0.022000	55.0	45.5
7.50	10.20	T132M-4	1445	15.50	88	0.83	6.7	2.70	3.0	0.029600	67.0	61.6
9.50	13.00	T132MA-4	1430	18.90	88	0.83	6.0	2.90	3.0	0.033200	78.0	72.4
11.00	15.00	T132MB-4	1440	21.70	90	0.82	6.0	2.50	2.7	0.038500	85.0	79.6
11.00	15.00	T160 M-4	1460	20.40	89	0.87	6.8	2.30	3.0	0.065500	-	100.0
15.00	20.40	T160 L-4	1460	27.50	90	0.87	7.5	2.50	3.1	0.089500	-	130.0

Rated Output		Type	Parameters at Rated Output				Starting characteristics			Torque of Inertia	Weight	
			Rotation speed	Current	Efficiency	Power Factor	Current	Torque			Cast Iron	All alloy
P <sub>2</sub>	Indication	n	I <sub>R</sub>	η	cosφ	I <sub>S</sub> /I <sub>R</sub>		M <sub>S</sub> /M <sub>R</sub>	M <sub>MAX</sub> /M <sub>R</sub>	J		
kW	HP	rpm	A	%					kg.m <sup>2</sup>	kg		

1000 rpm

0.12	0.16	T63B-6	880	0.60	51	0.60	2.8	2.0	2.1	0.000324	-	4.8
0.18	0.25	T71A-6	900	0.66	57	0.68	2.5	1.8	2.0	0.000930	-	5.4
0.25	0.34	T71B-6	880	0.91	60	0.66	2.8	1.9	2.0	0.001080	-	6.0
0.37	0.50	T80A-6	930	1.30	62	0.67	3.5	2.0	2.1	0.001940	-	8.0
0.55	0.75	T80B-6	925	1.91	66	0.65	3.3	2.0	2.3	0.002210	-	9.2
0.75	1.00	T90S-6	935	2.10	72	0.73	4.0	2.1	2.4	0.003740	18.0	13.3
1.10	1.50	T90L-6	930	2.90	75	0.75	4.8	2.3	2.4	0.004920	22.0	16.8
1.50	2.00	T100L-6	920	3.80	75	0.77	5.0	1.8	2.1	0.009030	28.0	20.5
2.20	3.00	T112M-6	940	5.60	78	0.76	4.9	2.0	2.5	0.014700	37.0	27.5
3.00	4.00	T132S-6	960	7.30	81	0.76	5.0	1.7	2.4	0.022400	48.0	45.0
4.00	5.50	T132MA-6	960	9.70	83	0.73	6.0	2.3	2.8	0.029600	58.0	51.7
5.50	7.50	T132MB-6	960	13.90	83	0.71	6.2	2.4	2.8	0.036000	67.0	60.8
7.50	10.20	T160M-6	965	15.60	88	0.80	6.5	2.2	3.3	0.073150	-	105.0
11.00	15.00	T160L-6	965	20.80	87	0.84	7.4	2.4	3.3	0.104500	-	130.0

750 rpm

0.09	0.12	T71A-8	690	0.68	38.8	-	1.9	2.0	2.5	0.00093	-	5.3
0.12	0.18	T71B-8	660	0.78	39.5	0.57	1.9	1.6	1.9	0.00108	-	6.0
0.18	0.25	T80A-8	700	0.95	48.0	0.58	2.3	1.7	2.1	0.00194	-	8.0
0.25	0.34	T80B-8	700	1.25	53.0	0.56	2.4	2.0	2.3	0.00221	-	9.2
0.37	0.50	T90S-8	680	1.25	63.0	0.67	3.2	1.6	1.9	0.00374	17.5	14.3
0.55	0.75	T90L-8	680	1.9	65.0	0.66	3.2	1.7	1.9	0.00492	22.0	16.8
0.75	1.00	T100LA-8	700	2.6	68.0	0.65	3.6	1.6	2.1	0.00672	25.5	18.0
1.10	1.50	T100LB-8	690	3.6	68.0	0.68	3.3	1.8	2.0	0.00786	28.0	20.5
1.50	2.00	T112M-8	705	4.6	73.0	0.65	4.3	2.2	2.5	0.01470	36.0	26.5
2.20	3.00	T132S-8	705	6.4	77.0	0.68	4.1	2.1	2.3	0.02630	49.0	44.0
3.00	4.00	T132M-8	705	8.3	78.0	0.70	4.1	2.1	2.4	0.03520	59.0	51.5

1500/3000 rpm

0.45/0.6	0.6/0.8	T80A-4/2	1440/2830	1.50/1.50	61/71	0.74/0.89	3.5/4.4	1.6/1.6	2.1/2.2	0.00128	-	8.2
0.60/0.8	0.8/1.0	T80B-4/2	1410/2830	1.90/1.80	68/73	0.71/0.88	3.5/5.0	1.7/1.6	2.2/2.3	0.00194	-	9.2
0.80/1.1	1.1/1.5	T90S-4/2	1440/2880	2.20/2.55	71/70	0.73/0.88	4.7/5.1	1.7/1.7	2.4/2.2	0.00255	17.3	13.3
1.10/1.5	1.5/2.0	T90L-4/2	1430/2840	2.75/3.30	73/72	0.79/0.92	4.5/5.0	1.8/1.7	2.3/2.2	0.00278	22.0	15.8
1.50/2.2	2.0/3.0	T90LC-4/2	1415/3850	3.56/4.89	77/75	0.80/0.87	4.5/4.7	2.3/2.1	2.5/2.3	0.00371	22.5	17.0
1.50/2.2	2.0/3.0	T100LA-4/2	1440/2845	3.70/4.80	78/75	0.79/0.90	5.9/5.4	1.9/1.5	2.5/2.1	0.00503	27.0	19.5
2.40/3.0	3.3/4.1	T100LB-4/2	1420/2855	5.50/6.40	78/78	0.83/0.90	5.6/6.7	2.0/2.0	2.4/2.4	0.00619	31.0	23.5
3.20/4.0	4.3/5.5	T112M-4/2	1425/2845	7.30/8.20	79/79	0.83/0.90	5.4/6.3	1.9/1.9	2.5/2.5	0.01090	38.0	28.2
4.00/5.5	5.5/7.5	T112MB-4/2	1420/2825	8.90/11.3	79/78	0.79/0.90	5.8/5.6	2.1/2.2	2.2/2.3	0.01280	40.5	30.8
4.50/5.5	5.1/7.4	T132S-4/2	1455/2905	9.90/11.2	83/79	0.81/0.91	5.1/6.2	1.9/2.2	2.4/2.5	0.02200	55.0	-
6.10/7.5	8.2/10.1	T132M-4/2	1450/2900	12.70/14.40	85/85	0.83/0.90	6.3/7.0	2.2/2.4	2.4/2.7	0.02960	67.0	-

750/1500 rpm

0.7/1.1	0.95/1.5	T100LA-8/4	700/1415	2.6/2.8	64/68	0.65/0.84	3.5/4.3	1.5/1.5	2.0/2.0	0.00672	25.5	18.0
0.9/1.5	1.40/2.2	T100LB-8/4	700/1415	3.4/3.5	64/74	0.64/0.87	3.3/4.8	1.6/1.4	2.2/2.0	0.00788	28.0	20.5
1.4/2.2	1.90/3.0	T112M-8/4	710/1430	4.5/4.6	69/78	0.66/0.89	3.8/5.8	1.9/1.7	2.3/2.4	0.01470	36.0	26.2
1.9/2.7	2.50/3.8	T132S-8/4	705/1420	5.0/5.9	77/78	0.75/0.90	4.0/4.7	1.6/1.5	2.0/2.1	0.02630	49.0	42.4
2.5/3.7	3.40/5.0	T132M-8/4	700/1420	6.4/8.0	78/78	0.76/0.87	3.9/4.9	1.8/1.7	2.0/2.0	0.03850	61.0	56.5

Rated Output		Type	Rotation speed	Current	Efficiency	Power Factor	$I_s/I_R$	$M_s/M_R$	$M_{MAX}/M_R$	Torque of Inertia	Weight	
Nennleistung		Typ	Nenn-drehzahl	Strom	Wir- gungs- grad	Leis- tungs- Fac- tor	Starting characteristics			Trägheits moment	Cast Iron	All alloy
$P_2$		Indication	n	$I_R$	$\eta$	$\cos\phi$	Als Vielfaches des				J	Gewicht
kW	HP		rpm	A	%		$I_s/I_R$	$M_s/M_R$	$M_{MAX}/M_R$	kg.m <sup>2</sup>	Grau- guss	Alumin- ium
											m	kg

3000 min<sup>-1</sup>

0.75	1.00	TH80 A-2	2900	1.95	78.8	0.70	6.6	3.8	3.85	0.00100	-	9.30
1.10	1.50	TH80 B-2	2870	2.50	80.5	0.79	5.9	3.4	3.50	0.00110	-	10.10
1.50	2.00	TH90 S-2	2915	3.80	82.1	0.74	7.0	3.6	3.80	0.00163	20.7	14.60
2.20	3.00	TH90 L-2	2890	4.60	83.8	0.83	7.0	3.6	3.80	0.00221	22.0	16.40
3.00	4.00	TH100 L-2	2885	6.00	84.7	0.85	7.2	3.4	3.60	0.00429	28.5	21.00
4.00	5.00	TH112 M-2	2925	8.00	86.4	0.81	8.0	3.8	3.90	0.07380	40.0	27.85
5.50	7.50	TH132 SA-2	2945	11.10	88.0	0.82	8.3	3.7	3.90	0.01420	56.0	41.00
7.50	10.20	TH132 SB-2	2935	14.90	88.3	0.83	8.2	3.7	3.90	0.01580	64.5	46.00
11.00	15.00	TH160 MA-2	2910	19.90	89.4	0.89	7.4	2.1	3.20	0.04500	-	108.0
15.00	20.40	TH160 MB-2	2915	26.65	90.3	0.90	7.5	2.4	3.40	0.05300	-	123.1
18.50	25.20	TH160 L-2	2910	32.30	90.9	0.91	7.9	2.9	3.60	0.06100	-	143.5

1500 min<sup>-1</sup>

0.75	1.00	TH80 B-4	1420	1.91	79.5	0.72	5.0	2.9	3.2	0.00197	-	11.90
1.10	1.50	TH90 S-4	1425	2.80	81.5	0.71	5.8	3.6	3.8	0.00339	21.50	15.80
1.50	2.00	TH90 L-4	1435	3.84	82.8	0.72	6.4	3.6	3.8	0.00410	23.80	19.00
2.20	3.00	TH100 LA-4	1445	5.35	84.3	0.72	6.9	3.7	3.8	0.00659	32.30	24.80
3.00	4.00	TH100 LB-4	1435	6.70	85.5	0.77	6.5	3.2	3.4	0.00782	34.50	27.45
4.00	5.50	TH112 M-4	1450	9.00	86.6	0.75	7.5	3.6	3.8	0.01400	46.30	34.50
5.50	7.50	TH132 S-4	1460	11.70	88.1	0.78	8.0	3.7	3.8	0.02960	67.00	49.00
7.50	10.20	TH132 M-4	1455	15.70	88.8	0.79	7.5	3.7	3.8	0.03320	-	77.50
11.00	15.00	TH160 M-4	1460	23.10	89.8	0.77	6.7	2.1	2.8	0.06500	-	136.00
15.00	20.40	TH160 L-4	1460	30.50	90.6	0.79	7.3	2.3	3.0	0.08300	-	161.00

1000 min<sup>-1</sup>

0.75	1.00	TH90 S-6	950	2.45	75.90	0.60	4.3	3.0	3.3	0.00492	20.80	16.00
1.10	1.50	TH90 L-6	945	3.10	78.10	0.66	4.6	2.9	3.3	0.00640	23.20	18.80
1.50	2.00	TH100 L-6	950	3.90	79.80	0.71	4.7	2.5	2.8	0.01120	26.20	22.15
2.20	3.00	TH112 M-6	955	5.55	81.80	0.70	5.6	3.0	3.1	0.01740	38.10	28.30
3.00	4.00	TH132 S-6	970	7.50	84.00	0.69	6.4	3.0	3.4	0.02960	58.50	41.00
4.00	5.50	TH132 MA-6	965	9.45	84.70	0.73	6.6	3.2	3.6	0.03600	66.50	49.00
5.50	7.50	TH132 MB-6	970	12.60	86.10	0.74	6.5	3.4	3.7	0.04570	-	77.50
7.50	10.20	TH160 M-6	965	16.20	87.20	0.77	4.7	1.9	2.2	0.07500	-	118.00
11.00	15.00	TH160 L-6	965	22.95	88.70	0.78	4.8	1.9	2.2	0.09800	-	143.00

TYPE OF EXECUTION B3

BAUFORM B3

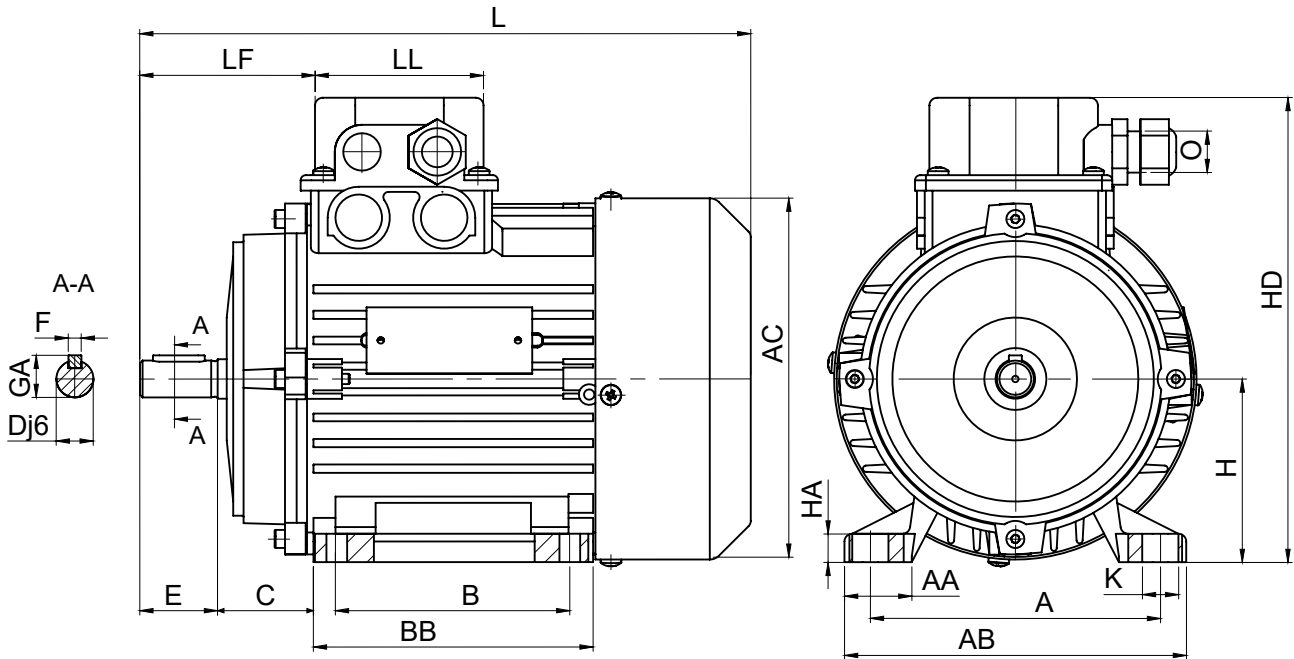

Type	Dimensions, mm																		
Typ	Abmessungen, mm																		
	A	AA	AB	AC	B	BB	C	D	E	F	GA	H	HA	HD	L	LF	LL	K	O
T63	100	20	120	123	80	105	40	11	23	4	125	63	10	165	216	50	65	7	M16
T71	112	24	136	140	90	108	45	14	30	5	16	71	11	183	236	65			
T, TH80	125	29	154	157	100	125	50	19	40	6	21	80	13	207	274	76	78	9.5	M20
T, TH90S					130	56	24	50	27	90	222	307	90						
T, TH90L, LB	140	34	174	220	125	155	63	28	60	8	31	100	14	332	375	106	112	15	M25
T, TH100L, LA, LB					175	70								264	389	109			
T, TH112M	190	34	224	220	140	177	70	89	38	80	10	41	132	16	312	451	135	91	15
T, TH132S, SA, AB	216	58	260	257	180	218	489												
T, TH132M, MA, MB-6	254	60	314	310	210	250	108	42	110	12	46	160	24	403	600	162	177	15	M25
T, TH160M					254	304									644				
T, TH160L																			

TYPE OF EXECUTION B5

BAUFORM B5

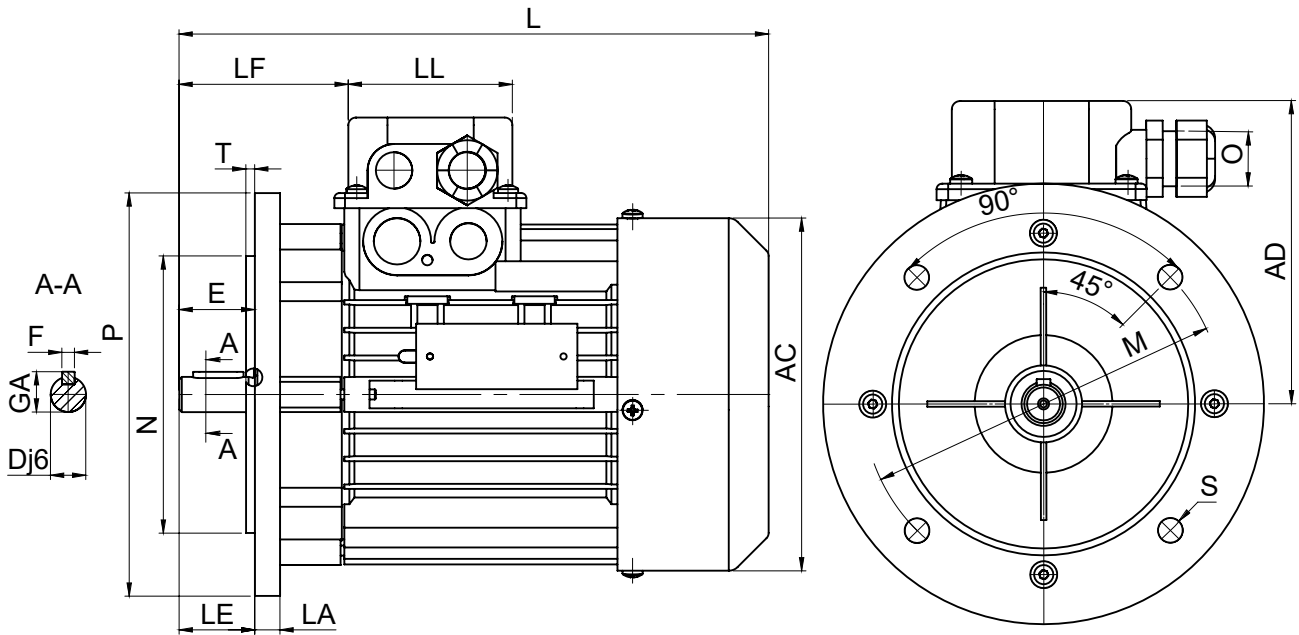

Type	Dimensions, mm																
Typ	Abmessungen, mm																
	Flange	AC	AD	D	E	F	GA	L	LE	LF	LL	M	N	O	P	S	T
T63	A100	123	102	11	23	4	12.5	218	23	50	65	115	95	M16	140	9	3
T71	A140 A160	140	112	14	30	5	16	236	30	65		130	110		160		
T, TH80	A160 A200	157	127	19	40	6	21.5	274	40	76	78	165	130	M20	200	12	3.5
T, TH90S	A160 A200	174	132	24	50	8	27	307	50	90		130	110		160	9	
T, TH90L, LB	A160 A200							130			110	160	9				
T, TH100L, LA, LB	A200 A250	192	142	28	60	31	375	60	106	109	215	180	M25	200	12	14	4
T, TH112M	A250													250			
T, TH132S, SA, AB	A216	257	180	36	80	10	41	451	80	136	91	285	230	M25	300	19	5
T, TH132M, MA, MB-6	A300							489									
T, TH160M	A350	310	243	42	110	12	46	600	110	162	177	300	250	M32	350	19	5
T, TH160L								644									

TYPE OF EXECUTION B14

BAUFORM B14

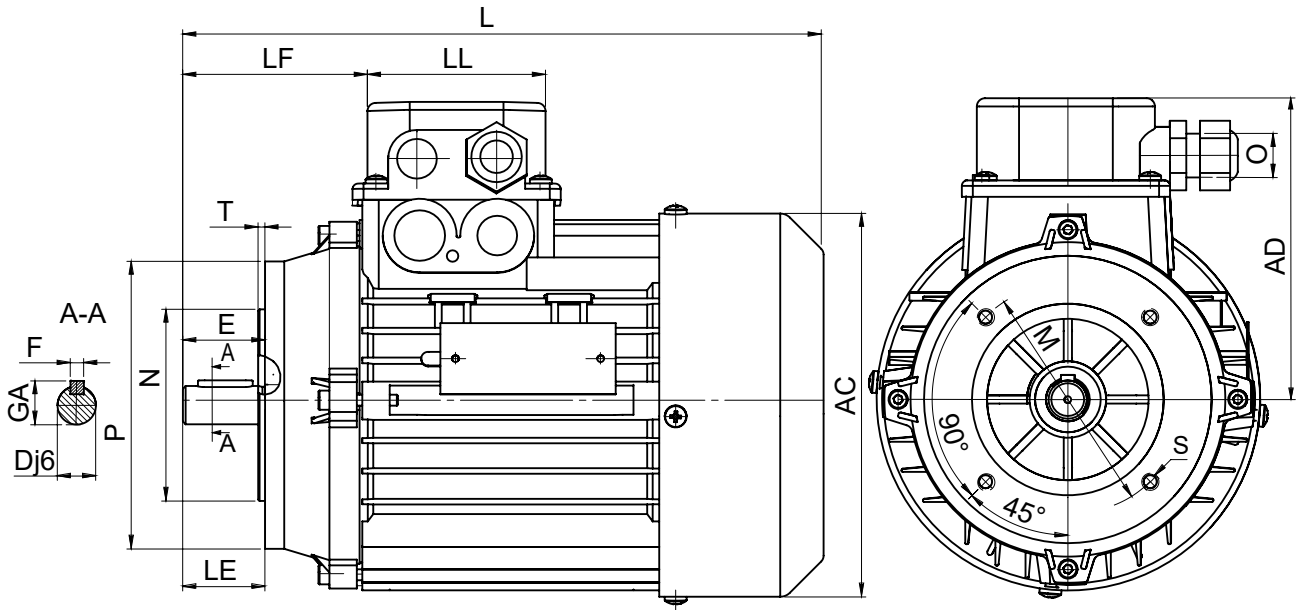

Type	Dimensions, mm																
Typ	Abmessungen, mm																
	Flande	AC	AD	D	E	F	GA	L	LE	LF	LL	M	N	O	P	S	T
T63	F75	123	102	11	23	4	12.5	218	23	50	65	75	60	M16	90	M5	2.5
	F100											100	80		120	M6	3
T71	F85	140	112	14	30	5	16	236	30	65	65	85	70	M16	105	M6	2.5
	F115											115	95		140	M8	3
T, TH80	F100	157	127	19	40	6	21.5	274	40	76	78	100	80	M20	120	M6	3
	F130											130	110		160	M8	3.5
T, TH90S	F115	174	132	24	50	8	27	307	50	90	78	115	95	M20	140	M8	3
	F130											130	110		160	M8	3.5
T, TH90L, LB	F115	174	132	24	50	8	27	332	50	90	78	115	95	M20	140	M8	3
	F130											130	110		160	M8	3.5
T, TH100L, LA, LB	F130	192	142	28	60	8	31	375	60	106	78	165	130	M20	200	M10	3.5
	F165											130	110		160	M8	3.5
T, TH112	F130	220	152	28	60	8	31	389	60	109	78	130	110	M20	160	M8	3.5
	F165											200	M8		3.5		
T, TH132S, SA, AB	F165	257	180	36	80	10	41	451	80	136	91	185	130	M25	200	M10	3.5
T, TH132M, MA, MB-6								489									

Rated Output		Type	Rotation speed	Current	Efficiency	Power Factor	$I_s/I_R$	$M_s/M_R$	$M_{MAX}/M_R$	Torque of Inertia	Weight	
Nennleistung		Typ	Nenn-drehzahl	Strom	Wir- gungs- grad	Leis- tungs-Fac- tor	Starting characteristics			Trägheits moment	Cast Iron	All alloy
$P_2$		Indication	n	$I_R$	$\eta$	$\cos\phi$	Als Vielfaches des				J	Gewicht
kW	HP		rpm	A	%		$I_s/I_R$	$M_s/M_R$	$M_{MAX}/M_R$	kg.m <sup>2</sup>	Grau- guss	Alumin- ium
										m	kg	

3000 min<sup>-1</sup>

0.75	1.00	TP80A-2	2865	1.6	80.7	0.83	7.0	2.7	3.4	0.0011	-	10.2
1.10	1.50	TP80B-2	2860	2.3	82.7	0.82	7.6	3.5	3.5	0.0013	-	10.3
1.50	2.00	TP90S-2	2870	3.0	84.2	0.84	7.8	2.0	3.6	0.0018	-	16.0
2.20	3.00	TP90L-2	2865	4.3	85.9	0.85	8.4	2.9	3.6	0.0022	-	20.0
3.00	4.00	TP100L-2	2880	5.7	87.1	0.87	8.4	3.6	3.9	0.0032	-	27.8
4.00	5.00	TP112M-2	2900	7.3	88.1	0.90	8.4	2.1	3.5	0.0082	-	33.2
5.50	7.50	TP132SA-2	2925	10.2	89.2	0.87	8.1	2.4	3.5	0.0143	-	50.0
7.50	10.20	TP132SB-2	2920	13.5	90.1	0.89	8.2	2.5	3.5	0.0170	-	67.0
11.00	15.00	TP160MA-2	2950	19.7	91.2	0.87	7.9	2.3	3.6	0.0554	-	85.0
15.00	20.40	TP160MB-2	2945	26.4	91.9	0.89	8.2	2.2	3.5	0.0690	-	96.1
18.50	25.20	TP160L-2	2945	32.0	92.4	0.90	8.2	2.4	3.5	0.0809	-	107.5

1500 min<sup>-1</sup>

0.75	1.00	TP80B-4	1430	1.70	82.5	0.77	6.3	2.8	2.8	0.0019	-	12.2
1.10	1.50	TP90S-4	1445	2.40	84.1	0.78	7.2	3.0	3.4	0.0032	-	21.0
1.50	2.00	TP90L-4	1440	3.23	84.2	0.78	7.4	3.2	3.5	0.0038	-	22.0
2.20	3.00	TP100LA-4	1455	4.50	85.9	0.81	8.0	2.7	3.2	0.0097	-	31.4
3.00	4.00	TP100LB-4	1455	6.00	87.1	0.83	8.1	2.9	3.3	0.0110	-	35.5
4.00	5.50	TP112M-4	1450	7.95	88.6	0.82	8.0	2.7	3.1	0.0175	-	35.4
5.50	7.50	TP132S-4	1460	10.80	89.6	0.82	6.9	2.0	2.8	0.0364	-	77.0
7.50	10.20	TP132M-4	1480	14.40	90.4	0.83	6.8	2.1	2.7	0.0429	-	87.0
11.00	15.00	TP160M-4	1475	20.70	91.4	0.84	7.3	2.4	3.2	0.01081	-	120.0
15.00	20.40	TP160L-4	1470	27.80	92.1	0.85	7.5	2.5	3.2	0.01389	-	131.0

1000 min<sup>-1</sup>

0.75	1.00	TP90S-6	945	2.00	78.9	0.69	5.6	2.7	3.4	0.0033	-	17.5
1.10	1.50	TP90L-6	949	2.84	81.0	0.69	5.4	3.2	3.2	0.0041	-	20.1
1.50	2.00	TP100L-6	965	3.62	82.5	0.72	6.6	2.6	3.1	0.0128	-	32.3
2.20	3.00	TP112M-6	960	5.04	84.3	0.75	6.5	2.7	3.0	0.0149	-	37.0
3.00	4.00	TP132S-6	970	6.60	85.6	0.77	5.6	1.9	2.4	0.0359	-	55.0
4.00	5.50	TP132MA-6	975	8.68	86.8	0.77	6.0	2.1	2.6	0.0451	-	65.0
5.50	7.50	TP132MB-6	975	11.80	88.0	0.77	6.2	2.2	2.7	0.0537	-	69.0
7.50	10.20	TP160M-6	975	14.90	89.1	0.82	5.6	1.8	2.4	0.1375	-	96.0
11.00	15.00	TP160L-6	975	21.90	90.3	0.80	6.1	2.1	2.7	0.1908	-	115.0

TYPE OF EXECUTION B3

BAUFORM B3

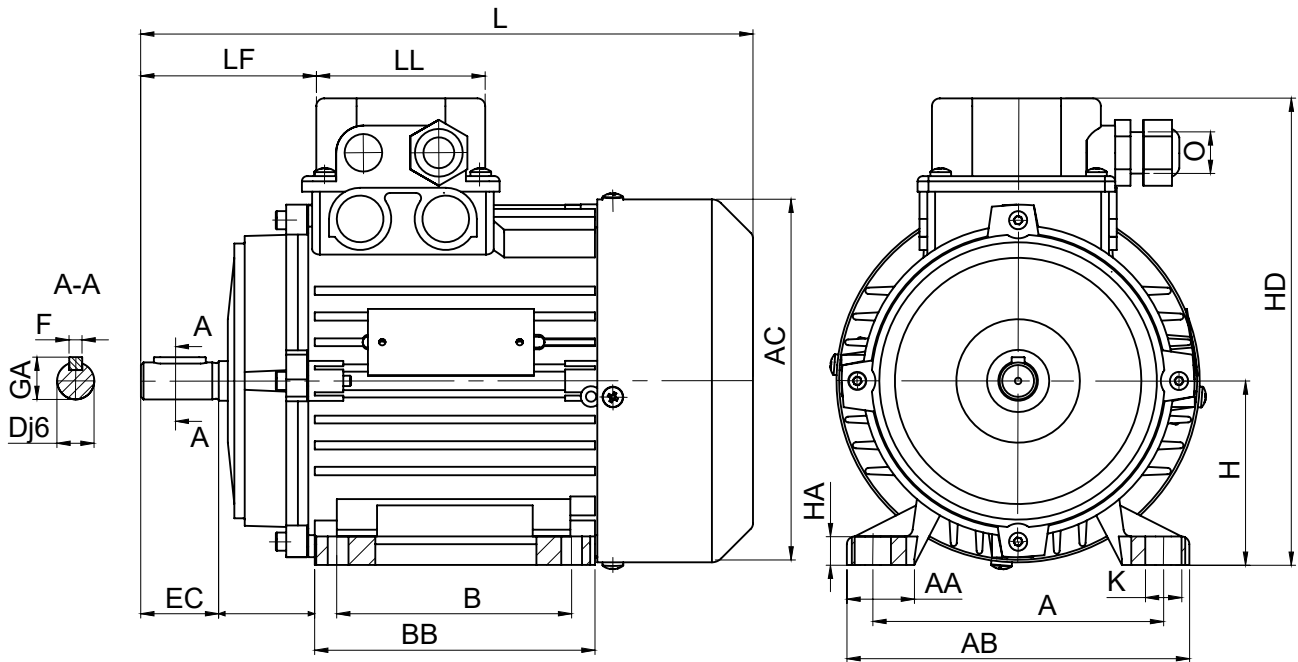

Type	Dimensions, mm																		
Typ	Abmessungen, mm																		
	A	AA	AB	AC	B	BB	C	D	E	F	GA	H	HA	HD	L	LF	LL	K	O
TP80	125	29	154	157	100	125	50	19	40	6	21.5	80	13	207	282	76	78	9.5	M20
TP90S	140	34	174	125		130	56	24	50	8	27	90	14	222	317	90			
TP90L					155	340													
TP100L,LA,LB	160	32	192	140	175	63	28	60	31	100	14	242	375	106					
TP112M	190	34	224		177	70							264	389	109				
TP132S,SA,SB	216	58	260	257	180	89	38	80	10	41	132	16	312	451	135	91	11.2	M25	
TP132M,MA,MB					178									218					515
TP160M	254	60	314	310	210	250	108	42	110	12	46	160	24	610	162	177			15
TP160L					254	304								660					

TYPE OF EXECUTION B5

BAUFORM B5

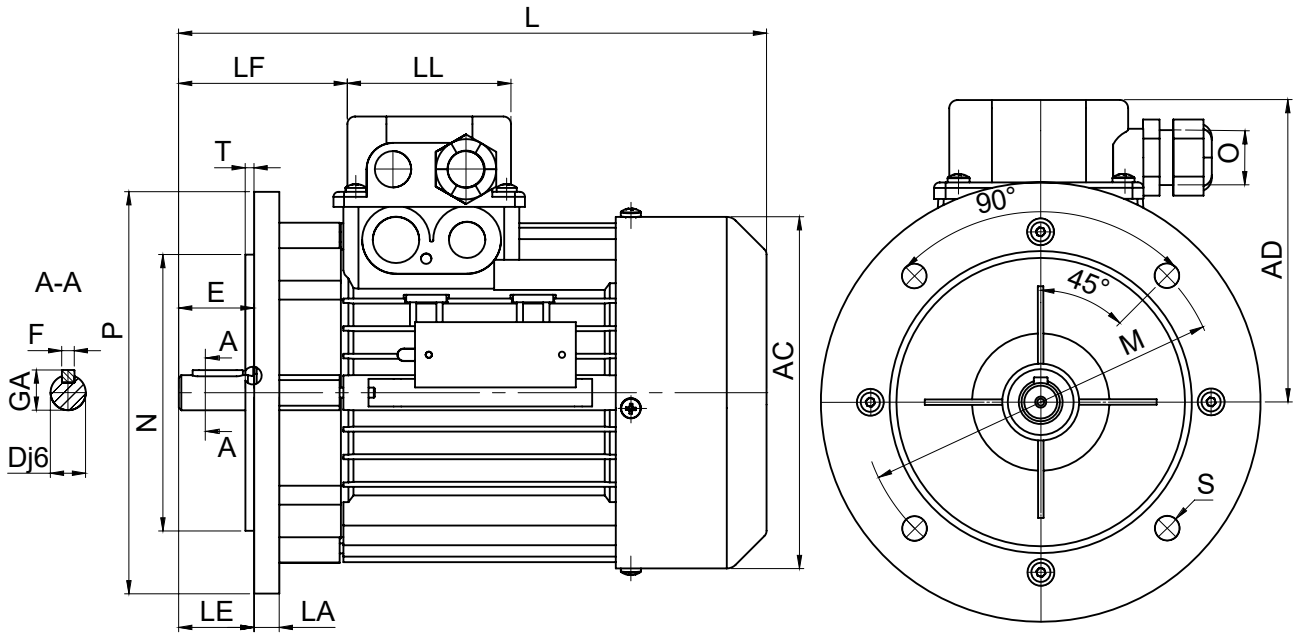

Type	Dimensions, mm																
Typ	Abmessungen, mm																
	Flande	AC	AD	D	E	F	GA	L	LE	LF	LL	M	N	O	P	S	T
TP80	A160	157	127	19	40	6	21.5	282	40	76		130	110		160	9	
	A200											165	130		200	12	
TP90S	A160	174	132	24	50	8	27	317	50	90	78	130	110	M20	160	9	3.5
	A200											165	130		200	12	
TP90L	A160	174	132	24	50	8	27	340	50	90	78	130	110	M20	160	9	3.5
	A200											165	130		200	12	
TP100L,LA,LB	A200	192	142	28	60	8	31	375	60	108		165	130		200	12	
	A250											215	180		250	14	
TP112M	A250	220	152					389		109		215	180		250	14	4
TP132S,SA,SB	A300	257	180	38	80	10	41	451	80	135	91	265	230	M25	300		
TP132M,MA,MB								515									
TP160M	A350	310	243	42	110	12	48	610	110	162	177	300	250	M32	350	19	5
TP160L								660									

TYPE OF EXECUTION B14

BAUFORM B14

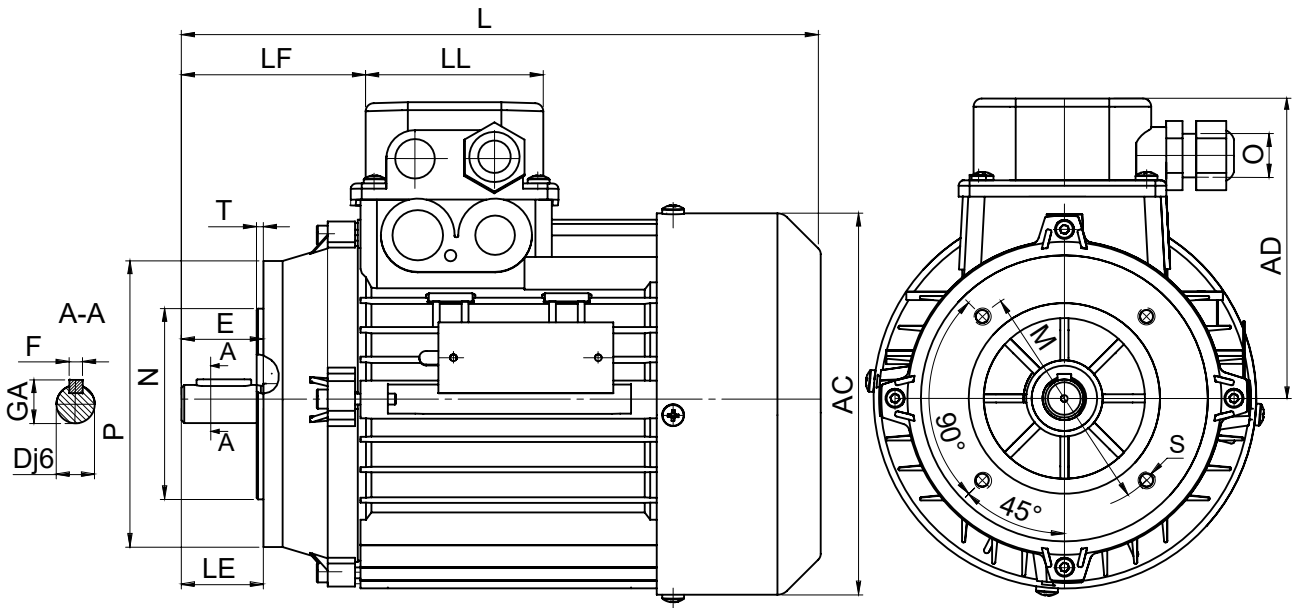

Type	Dimensions, mm																
Typ	Abmessungen, mm																
	Flande	AC	AD	D	E	F	GA	L	LE	LF	LL	M	N	O	P	S	T
TP90	F100	157	127	19	40	6	21.5	282	40	76		100	80		120		3
	F130											130	110		160		3.5
TP90S	F115	174	132	24	50		27	317	50	90		115	95		140	M8	3
	F130											130	110		160		3.5
TP90L	F115	174	132	24	50		27	340	50	90	78	115	95	M20	140		3
	F130											130	110		160		
TP100L,LA,LB	F130	192	142	28	60		31	375	60	106		130	110		160		3.5
	F165											165	130		200		
TP112M	F130	220	152	28	60		31	389	60	109		130	110		160	M8	3.5
	F165											200					
TP132S,SA,SB	F165	257	180	38	80	10	41	451	80	135	91	165	130	M25	200	M10	
TP132M,MA,MB								515									

Rated Output		Type	Rotation speed	Current	Efficiency	Power Factor	I <sub>S</sub> /I <sub>R</sub>	M <sub>S</sub> /M <sub>R</sub>	M <sub>MAX</sub> /M <sub>R</sub>	Torque of Inertia	Weight	
							Starting characteristics				Cast Iron	All alloy
Nennleistung		Typ	Nenn-drehzahl	Strom	Wirgungs-grand	Leis-tungs-Fac-tor	I <sub>S</sub> /I <sub>R</sub>	M <sub>S</sub> /M <sub>R</sub>	M <sub>MAX</sub> /M <sub>R</sub>	Trägheits moment	Gewicht	
							Als Vielfaches des				Grauguss	Alu-minium
P <sub>2</sub>		Indication	n	I <sub>R</sub>	η	cosφ	I <sub>S</sub> /I <sub>R</sub>	M <sub>S</sub> /M <sub>R</sub>	M <sub>MAX</sub> /M <sub>R</sub>	J	m	
kW	HP		rpm	A	%					kg.m <sup>2</sup>	kg	

3000 min<sup>-1</sup> S1, S4 - 40% 240 h<sup>-1</sup>

0.18	0.25	T63A-2 BR	2770	0.49	64	0.81	3.9	2.10	2.4	1.25/2.5	0.0005844	6.5
0.25	0.25	T63B-2 BR	2770	0.67	69	0.78	4.1	2.25	2.5	1.25/2.5	0.0006314	6.9
0.37	0.50	T71A-2 BR	2800	0.91	71	0.83	4.3	2.20	2.4	2.5/5	0.000943	8.5
0.55	0.75	T71B-2 BR	2790	1.33	71	0.81	4.1	2.30	2.4	2.5/5	0.000962	8.8
0.75	1.00	T80A-2 BR	2820	1.90	72	0.82	5.0	2.40	2.6	5/10	0.002805	11.5
1.10	1.50	T80B-2 BR	2820	2.55	77	0.81	5.3	2.60	2.6	5/10	0.002905	12.7
1.50	2.00	T80C-2 BR	2850	3.80	75	0.76	6.0	2.30	3.0	5/10	0.003105	13.2
1.50	2.00	T90S-2 BR	2875	3.30	77	0.82	6.6	2.70	3.0	10/20	0.004040	16.8
2.20	3.00	T90L-2 BR	2860	4.80	80	0.85	6.8	3.10	3.2	10/20	0.004230	20.3
3.00	4.00	T110L-2 BR	2880	6.20	82	0.87	7.2	2.50	2.7	15/30	0.008520	25.4
4.00	5.50	T112M-2 BR	2870	8.20	83	0.88	7.2	2.70	3.0	20/40	0.011530	33.2
5.50	7.50	T132SA-2 BR	2900	11.20	85	0.87	6.0	2.30	3.1	35/70	0.033800	-
7.50	10.20	T132SB-2 BR	2905	14.30	85	0.89	7.0	2.10	2.8	35/70	0.036500	-
9.20	12.50	T132MA-2 BR	2890	18.00	85	0.89	7.0	2.10	2.8	35/70	0.036563	-
11.00	15.00	T132MB-2 BR	2890	21.00	84	0.88	7.5	2.50	3.2	35/70	0.036750	-
11.00	15.00	T160MA-2 BR	2910	20.30	88	0.90	6.0	2.00	2.5	110	0.026790	-
15.00	20.40	T160MB-2 BR	2915	27.30	89	0.90	7.2	2.40	2.9	110	0.037000	-
18.50	25.20	T160L-2 BR	2910	32.60	90	0.92	7.2	2.40	3.0	150	0.045930	-

1500 min<sup>-1</sup> S1, S4-40% 240 h<sup>-1</sup>

0.12	0.16	T63A-4 BR	1340	0.42	59	0.70	3.0	2.0	2.1	1.25/2.5	0.0006204	5.7
0.18	0.25	T63B-4 BR	1320	0.58	62	0.72	3.0	2.0	2.0	1.25/2.5	0.0006744	6.1
0.25	0.34	T71A-4 BR	1350	0.79	65	0.70	3.1	2.0	2.1	2.5/5	0.001200	8.5
0.37	0.50	T71B-4 BR	1360	1.12	66	0.72	3.2	2.1	2.2	2.5/5	0.001330	9.4
0.55	0.75	T80A-4 BR	1400	1.62	69	0.74	3.7	1.8	2.2	5/10	0.003185	11.5
0.75	1.00	T80B-4 BR	1400	2.20	71	0.70	4.4	2.2	2.5	5/10	0.003445	12.7
1.10	1.50	T90S-4 BR	1410	2.80	75	0.78	4.6	2.2	2.4	10/20	0.004960	16.7
1.50	2.00	T90L-4 BR	1400	3.65	76	0.80	4.8	2.2	2.6	10/20	0.005190	19.3
2.20	3.30	T100LA-4 BR	1410	5.10	79	0.82	5.6	2.2	2.6	15/30	0.009830	25.0
3.00	4.00	T100LB-4 BR	1410	6.80	81	0.82	5.8	2.7	2.8	15/30	0.010990	28.9
4.00	5.50	T112M-4 BR	1420	8.70	82	0.83	6.0	2.7	2.9	20/40	0.016600	35.8
5.50	7.50	T132M-4 BR	1440	11.50	85	0.83	6.2	2.6	2.8	35/70	0.044300	-
7.50	10.20	T132MA-4 BR	1445	15.50	86	0.83	6.7	2.7	3.0	35/70	0.051900	-
9.50	13.00	T132MB-4 BR	1430	18.90	88	0.83	6.0	2.9	3.0	35/70	0.052100	-
11.00	13.00	T160M-4 BR	1460	20.40	89	0.87	6.8	2.3	3.0	110	0.065500	-
15.00	20.40	T160L-4 BR	1460	27.50	90	0.87	7.5	2.5	3.1	150	0.089500	-

Rated Output		Type	Rotation speed	Current	Efficiency	Power Factor	$I_S/I_R$	$M_S/M_R$	$M_{MAX}/M_R$	Brake moment	Moment of Inertia	Weight
Nennleistung		Typ	Nenn-drehzahl	Strom	Wirkungs-grad	Leis-tungs-Fac-tor	Starting characteristics			Brems-moment	Trägheits-moment	Gewicht
$P_2$		Indication	n	$I_R$	$\eta$	$\cos\phi$	Als Vielfaches des			Mbr	J	m
kW	HP		rpm	A	%		$I_S/I_R$	$M_S/M_R$	$M_{MAX}/M_R$	Nm	kg.m <sup>2</sup>	kg

1000 min<sup>-1</sup> S1, S4 - 40% 240 h<sup>-1</sup>

0.18	0.25	T71A-6 BR	900	0.66	57	0.88	2.5	1.8	2.0	2.5/5	0.001540	8.5
0.25	0.34	T71B-6 BR	880	0.91	80	0.88	2.8	1.9	2.0	2.5/5	0.001890	9.0
0.37	0.50	T80A-6 BR	930	1.30	62	0.67	3.5	2.0	2.1	5/10	0.003845	11.5
0.55	0.75	T80B-6 BR	925	1.91	84	0.66	3.3	2.0	2.3	5/10	0.004115	12.5
0.75	1.00	T90S-6 BR	935	2.10	72	0.73	4.0	2.1	2.4	10/20	0.008150	17.3
1.10	1.50	T90L-6 BR	930	2.90	75	0.75	4.6	2.3	2.4	10/20	0.007330	20.8
1.50	2.00	T100L-6 BR	920	4.00	75	0.77	5.0	1.8	2.1	15/30	0.013880	25.9
2.20	3.00	T112M-6 BR	940	5.90	78	0.78	4.9	2.0	2.5	20/40	0.020400	34.3
3.00	4.00	T132S-8 BR	960	7.30	81	0.76	5.0	1.7	2.4	35/70	0.044700	-
4.00	5.50	T132MA-6 BR	960	9.70	83	0.73	6.0	2.3	2.8	35/70	0.051900	-
5.50	7.50	T132MB-6 BR	960	13.90	83	0.71	6.2	2.4	2.8	35/70	0.058300	-
7.50	10.20	T160M-6 BR	988	15.60	88	0.80	6.5	2.2	3.3	110	0.073150	-
11.03	15.00	T160L-6 BR	965	20.80	87	0.84	7.4	2.4	3.3	150	0.104500	-

1500/3000 min<sup>-1</sup> S1, S4-20/40% 240 h<sup>-1</sup>

0.45/0.13	0.6/0.8	T80A-4/2 BR	1410/2830	1.5	81/71	0.74/0.89	3.5/4.4	1.8	2.1/2.2	5/10	0.003185	12.0
0.6/0.8	0.8/1.0	T80B-4/2 BR	1410/2830	1.9/1.8	66/73	0.71/0.88	3.5/5.0	1.7/1.6	2.2/2.3	5/10	0.003445	13.2
0.8/1.1	1.1/1.5	T90S-4/2 BR	1440/2800	2.3/2.7	71/70	0.73/0.88	4.7/5.1	1.7	2.4/2.2	10/20	0.005190	17.3
1.1/1.5	1.5/2.0	T90L-4/2 BR	1430/2840	2.9/3.5	73/72	0.79/0.92	4.5/5.0	1.8/1.7	2.3/2.2	10/20	0.005190	19.9
1.5/2.0	2.2/3.3	T100LA-4/2 BR	1440/2845	3.7/4.9	78/75	0.79/0.90	5.9/5.4	1.9/1.5	2.5/2.1	15/30	0.009830	25.5
2.4/3.3	3.3/4.1	T100LB-4/2 BR	1420/2855	5.8/8.7	78	0.83/0.90	5.6/6.7	2.0	2.4	15/30	0.010990	29.4
3.2/4.3	4.0/4.3	T112M-4/2 BR	1425/2845	7.7/8.6	89	0.83/0.93	5.4/8.3	1.9	2.5	20/40	0.016600	36.7
4.5/6.1	5.5/7.4	T132S-4/2 BR	1455/2905	9.9/11.2	83/79	0.81/0.91	5.1/6.2	1.9/2.2	2.4/2.5	35/70	0.044300	60.0
6.1/8.2	7.5/10.1	T132M-4/2 BR	1450/2900	12.7/14.4	86/85	0.83/0.90	6.3/7.0	2.2/2.4	2.4/2.7	35/70	0.051900	72.0

750/1500 min<sup>-1</sup> S1, S4-20/40% 240 h<sup>-1</sup>

0.7/1.1	0.95/1.5	T100LA-8/4 BR	700/1415	2.6/2.7	64/68	0.65/0.84	3.5/4.3	1.5	2.0	15/30	0.011520	23.9
0.9/1.5	1.40/2.2	T100LB-8/4 BR	700/1415	3.4/3.5	64/74	0.84/0.87	3.3/4.8	1.6/1.4	2.2/2.0	15/30	0.012660	26.4
1.4/2.2	1.90/3.0	T112M-8/4 BR	710/1430	4.5/4.6	69/78	0.66/0.89	3.8/5.8	1.9/1.7	2.3/2.4	20/40	0.020400	34.2
1.9/2.5	2.70/3.6	T132S-8/4 BR	705/1420	5.0/5.9	77/76	0.75/0.90	4.0/4.7	1.6/1.5	2.0/2.1	35/70	0.048600	54.0
2.5/3.4	3.70/5.0	T132M-8/4 BR	700/1420	6.4/8.0	76/78	0.75/0.87	3.9/4.9	1.8/1.7	2.0	35/70	0.060800	65.0

Rated Output		Type	Rotation speed	Current	Efficiency	Power Factor	$I_S/I_R$	$M_S/M_R$	$M_{MAX}/M_R$	Brake moment	Moment of Inertia	Weight
Nennleistung		Typ	Nenn-drehzahl	Strom	Wirkungs-grad	Leis-tungs-Fac-tor	Starting characteristics			Brems-moment	Trägheits-moment	Gewicht
$P_2$		Indication	n	$I_R$	$\eta$	$\cos\phi$	Als Vielfaches des			Mbr	J	m
kW	HP		rpm	A	%		$I_S/I_R$	$M_S/M_R$	$M_{MAX}/M_R$	Nm	kg.m <sup>2</sup>	kg

500/1500 min<sup>-1</sup> S1, S4 - 20/40% 240 h<sup>-1</sup>

0.05/0.15	0.08/0.20	T71A-12/4 BR	460/1440	0.93/0.69	11/15	0.70/0.72	1.2/3.2	1.9/1.8	2.3/2.4	2.5/2	0.001540	9.5
0.06/0.20	0.08/0.28	T71B-12/4 BR	470/1440	0.94/0.71	15/60	0.68/0.71	1.3/3.5	1.95/1.8	2.4/2.5	2.5/5	0.001700	10.1
0.08/0.25	0.11/0.34	T80A-12/4 BR	440/1450	1.30/1.30	14/43	0.74/0.65	1.2/2.8	2.1/2.1	2.7/3.3	4/10	0.003845	11.5
0.12/0.37	0.18/0.50	T80B-12/4 BR	440/1450	1.80/1.80	14/47	0.71/0.64	1.2/2.6	2.3/2.1	2.8/3.2	4/10	0.004115	12.5
0.18/0.55	0.24/0.75	T90S-12/4 BR	450/1420	2.10/1.60	16/66	0.71/0.78	1.3/4.2	1.8/1.95	2.2/2.7	10/20	0.006150	16.6
0.25/0.75	0.54/1.00	T90L-12/4 BR	450/1430	2.70/2.20	21/83	0.65/0.74	1.3/3.3	2.0/1.9	2.3/2.9	10/20	0.007330	26.5
0.37/1.10	0.50/1.50	T100LA-12/4 BR	440/1420	3.40/3.00	25/87	0.65/0.81	1.1/1.2	1.8/1.9	2.0/2.4	20/30	0.013860	26.0
0.55/1.50	0.75/2.00	T100LB-12/4 BR	430/1410	5.00/4.00	28/88	0.65/0.82	1.2/1.2	1.8/1.92	2.0/2.4	20/30	0.013880	29.0
0.75/2.20	1.00/3.00	T112M-12/4 BR	450/1400	6.50/8.00	33/70	0.54/0.85	1.3/1.3	1.8/1.9	2.1/2.5	25/40	0.020400	35.8
1.33/4.00	1.80/5.50	T132MA-12/4 BR	460/1450	7.70/8.90	48/80	0.56/0.83	1.5/4.0	1.9/2.0	2.3/2.6	35/70	0.051900	65.0
1.66/5.00	2.30/6.80	T132MB-12/4 BR	470/1450	9.10/11.0	49/81	0.57/0.84	1.6/5.0	1.9/2.1	2.3/2.6	35/70	0.058300	72.0
2.70/8.50	3.60/11.3	T160M-12/4 BR	480/1460	14.0/18.0	66/86	0.47/0.82	1.5/5.0	2.0/2.1	2.2/2.8	110	0.058485	109.0
4.00/12.0	5.30/18.0	T160L-12/4 BR	470/1450	18.0/29.0	68/87	0.48/0.73	1.6/5.1	1.9/2.0	2.3/2.8	150	0.058745	140.0

750/3000 min<sup>-1</sup> S1, S4 - 20/40% 240 h<sup>-1</sup>

0.023/0.09	0.031/0.12	T63A-8/2 BR	670/2830	0.3/0.3	16/51	0.66/0.75	1.4/1.4	1.5/2.2	1.8/3.0	1.25	0.0006204	6.6
0.03/0.12	0.04/0.16	T63B-8/2 BR	650/2800	0.34/0.39	18/52	0.72/0.79	1.4/3.6	1.5/2.1	1.5/2.3	1.25	0.0006744	7.0
0.045/0.18	0.06/0.25	T71A-8/2 BR	660/2730	0.5/0.6	18/54	0.60/0.82	1.5/3.3	1.5/2.0	2.9/4.7	2.50	0.0012000	8.8
0.06/0.24	0.08/0.32	T71B-8/2 BR	710/2830	0.75/0.76	19/55	0.64/0.88	1.5/3.3	2.0/2.1	3.0/4.8	2.50	0.0013300	9.7
0.075/0.3	0.10/0.4	T80A-8/2 BR	720/2910	1.1/1.1	18/59	0.62/0.77	2.0/5.1	2.3/2.3	4.5/6.1	4.00	0.0031850	12.0
0.13/0.55	0.18/0.75	T80B-8/2 BR	720/2880	1.4/1.7	23/63	0.60/0.79	2.0/4.0	2.3/2.2	3.6/3.1	4.00	0.0034450	13.0
0.18/0.24	0.24/1.0	T90S-8/2 BR	700/2800	1.7/1.9	25/65	0.58/0.87	2.2/6.7	2.1/2.0	3.5/3.0	10.00	0.0035820	17.0
0.25/1.1	0.34/1.5	T90L-8/2 BR	720/2890	2.2/2.6	30/70	0.54/0.90	3.0/5.0	2.2/2.0	3.0/4.0	10.00	0.0051900	19.3
0.37/1.5	0.5/2.0	T100LA-8/2 BR	720/2880	2.7/3.2	33/78	0.80/0.90	2.0/5.0	1.9/2.0	3.0/3.0	20.00	0.0098300	25.0
0.55/2.2	0.75/3.0	T100LB-8/2 BR	720/2900	3.7/4.7	40/79	0.50/0.90	2.0/5.0	1.9/2.4	3.0/3.0	20.00	0.0109900	28.9
0.75/3.0	1.0/4.0	T112M-8/2 BR	730/2900	5.3/7.5	40/72	0.50/0.86	3.0/6.0	2.3/2.3	3.3/3.4	25.00	0.0166000	35.8

TYPE OF EXECUTION B3

BAUFORM B3

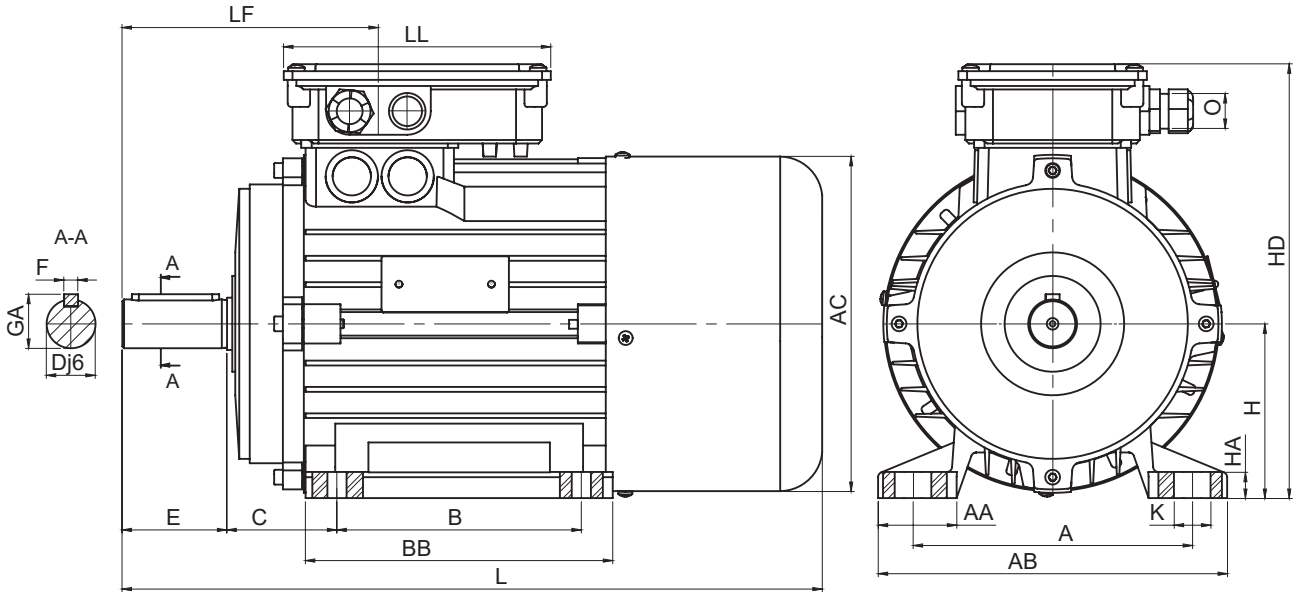

Type	Dimensions, mm																		
Typ	Abmessungen, mm																		
	A	AA	AB	AC	B	BB	C	D	E	F	GA	H	HA	HD	L	LF	LL	K	O
T63 BR	100	20	10	123	80	105	40	11	23	4	125	63	10	180	242	37	134	7	M16
T71 BR	112	24	136	140	90	108	45	14	30	5	16	71	11	198	262	51			
T80 BR	125	29	154	157	100	125	50	19	40	6	21.5	80	13	216	295	62	153	9.5	M20
T90S BR	140	34	174	174		130	56	24	50	8	27	90	14	239	336	76			
T90L, LB, LC BR					125	155									361				
T100LA, LB BR					160	32									192			192	
T112 BR	190	34	224	220	177	70	272	431	94										
T132S BR	216	44	260	257	140	180	89	38	80	10	41	132	16	327	512	125	206	12	M32
T132M BR						176									218				
T160M BR	254	63	318	309	210	264	116	42	110	12	46	180	23	403	677	252	187	15	
T160L BR					254	308									721				

TYPE OF EXECUTION B5

BAUFORM B5

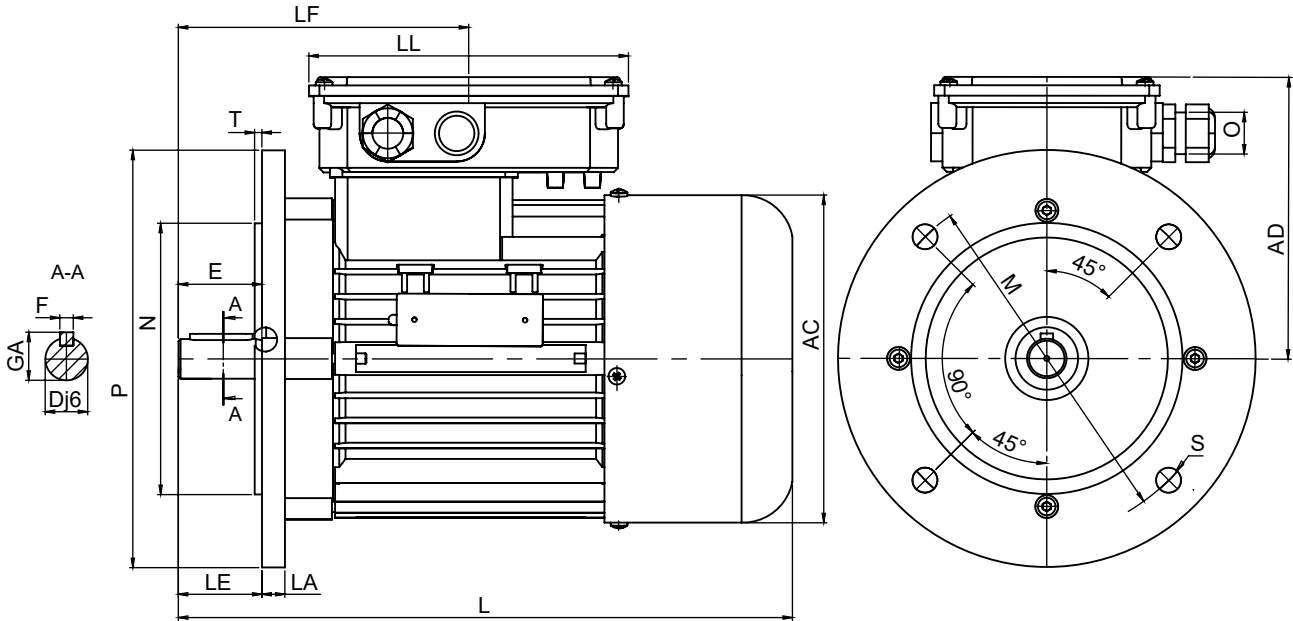

Type	Dimensions, mm																	
Typ	Abmessungen, mm																	
	Flande	AC	AD	D	E	F	GA	L	LA	LE	LF	LL	M	N	O	P	S	T
T63 BR	A140	123	117	11	23	4	12.5	242	10.5	23	37	134	115	95	M16	140	9	3
T71 BR	A140 A160	140	127	14	30	5	16	262	10	30	51		130	110		160		
T80 BR	A160 A200	157	136	19	40	6	21.5	295	11	40	62	153	165	130	M20	200	12	3.5
T90S BR	A160 A200	174	149	24	50	27	361	50		76	130		110	165		130	200	
T90L, LB BR	A160 A200								130		110	160	9	200	12			
T100L, LA, LB BR	A200 A250	192	150	28	60	8	31	406	15	60	92	153	215	180	M20	250	14	4
T112 BR	A250	220	160					431		94	250							
T132S BR	A300	257	188	38	80	10	41	512	20	80	125	206	265	230	M32	300	19	5
T132M BR								550										
T160M BR	A350	309	243	42	110	12	46	677	14	110	252	187	300	250	M32	350	19	5
T160L BR								721										

TYPE OF EXECUTION B14

BAUFORM B14

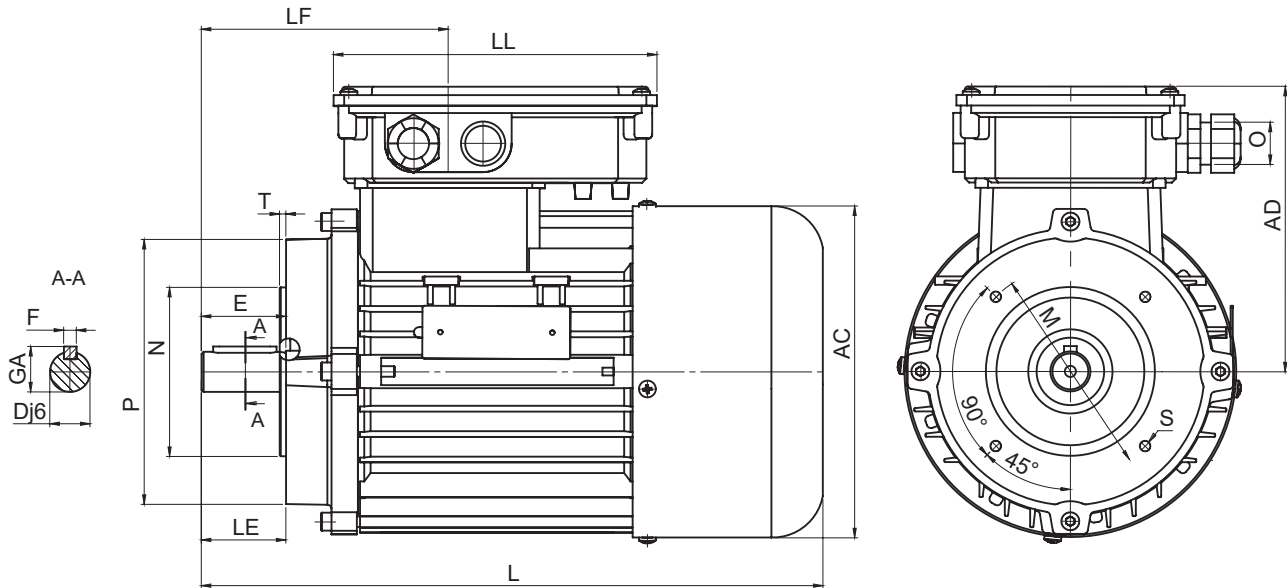

Type	Dimensions, mm																
Typ	Abmessungen, mm																
	Flande	AC	AD	D	E	F	GA	L	LE	LF	LL	M	N	O	P	S	T
T63 BR	F75	123	117	11	23	4	12.5	242	23	37	134	75	60	M16	90	M5	25
	F100											100	80		120	M6	3
T71 BR	F85	140	127	14	30	5	16	262	30	51	134	85	70	M16	105	M6	25
	F115											115	95		140	M8	3
T80 BR	F100	150	136	19	40	6	21.5	295	40	52	153	100	80	M20	120	M6	3
	F130											130	110		160	3.5	
T90S BR	F115	157	149	24	50	8	27	336	50	76	153	115	95	M20	140	M8	3
	F130							130				110	160		3.5		
T90L, LB BR	F115	157	149	24	50	8	27	361	50	76	153	115	95	M20	140	M8	3
	F130							130				110	160		3.5		
T100L, LA, LB BR	F130	192	150	28	60	8	31	406	60	92	153	130	110	M20	160	M10	3.5
	F165							165				130	200		M8		
T112 BR	F130	220	160	28	60	8	31	431	60	94	153	130	110	M20	160	M8	3.5
	F165							200				M8					
T132S BR	F165	257	188	38	80	10	41	512	80	125	206	165	130	M32	200	M10	4
T132M BR								550									

Rated Output		Type	Rotation speed	Current	Efficiency	Power Factor	$I_S/I_R$	$M_S/M_R$	$M_{MAX}/M_R$	Brake moment	Moment of Inertia	Weight
Nennleistung		Typ	Nenn-drehzahl	Strom	Wirkungs-grad	Leis-tungs-Fac-tor	Starting characteristics			Brems-moment	Trägheits-moment	All alloy
$P_2$		Indication	n	$I_R$	$\eta$	$\cos\phi$	Als Vielfaches des			Mbr	J	Aluminium
kW	HP		rpm	A	%		$I_S/I_N$	$M_S/M_N$	$M_M/M_N$	Nm	kg.m <sup>2</sup>	kg

3000 min<sup>-1</sup> S1, S4 - 40% 240 h<sup>-1</sup>

0.18	0.25	T63A-2 BR B5	2770	0.49	64	0.81	3.9	2.10	2.4	1.25/2.5	0.0005844	6.5
0.25	0.34	T63B-2 BR B5	2770	0.67	69	0.78	4.1	2.25	2.5	1.25/2.5	0.0006314	6.9
0.37	0.50	T71A-2 BR B5	2800	0.91	71	0.83	4.3	2.20	2.4	2.50/5.0	0.0009430	8.5
0.55	0.75	T71B-2 BR B5	2790	1.33	71	0.81	4.1	2.30	2.4	2.5/5.0	0.0009620	8.8
0.75	1.00	T80A-2 BR B5	2820	1.90	72	0.82	5.0	2.40	2.6	5.0/10.0	0.0028050	11.5
1.1	1.50	T80B-2 BR B5	2820	2.55	77	0.81	5.3	2.60	2.6	5.0/10.0	0.0029050	12.7
1.5	2.00	T90S-2 BR B5	2875	3.30	77	0.82	6.6	2.70	3.0	10.0/20.0	0.0040400	16.8
2.2	3.00	T90L-2 BR B5	2860	4.80	80	0.85	6.8	3.10	3.2	10.0/20.0	0.0042300	20.3
3.0	4.00	T100L-2 BR B5	2880	6.20	82	0.87	7.2	2.50	2.7	15.0/30.0	0.0085200	25.4
4.0	5.50	T112M-2 BR B5	2870	8.20	83	0.88	7.2	2.70	3.0	20.0/40.0	0.0115300	33.2
5.5	7.50	T132SA-2 BR B5	2900	11.20	85	0.87	6.0	2.30	3.1	35.0/70.0	0.0338000	-
7.5	10.20	T132SB-2 BR B5	2905	14.20	85	0.89	7.0	2.10	2.8	35.0/70.0	0.0365000	-
9.2	12.50	T132MA-2 BR B5	2905	18.00	84	0.88	7.5	2.50	3.2	35.0/70.0	0.0367000	-
11.0	15.00	T132MB-2 BR B5	2890	21.00	88	0.90	7.8	3.30	3.3	35.0/70.0	0.0368000	-
11.0	15.00	T160MA-2 BR B5	2910	20.30	88	0.90	6.0	2.10	2.5	110	0.0369000	-
15.0	20.40	T160MB-2 BR B5	2915	27.30	89	0.90	7.2	2.40	2.9	110	0.0370000	-
18.5	25.20	T160L-2 BR B5	2910	32.60	90	0.92	7.2	2.40	3.0	150	0.0459300	-

1500 min<sup>-1</sup> S1, S4 - 40% 240 h<sup>-1</sup>

0.12	0.16	T63A-4 BR B5	1340	0.42	59	0.70	3.0	2.0	2.1	1.25/2.5	0.0006204	5.7
0.18	0.25	T63B-4 BR B5	1320	0.58	62	0.72	3.0	2.0	2.0	1.23/2.5	0.0067440	6.1
0.25	0.34	T71A-4 BR B5	1350	0.79	65	0.70	3.1	2.0	2.1	2.50/5.0	0.0012000	8.5
0.37	0.50	T71B-4 BR B5	1360	1.12	66	0.72	3.2	2.1	2.2	2.50/5.0	0.0013300	9.4
0.55	0.75	T80A-4 BR B5	1400	1.62	69	0.74	3.7	1.8	2.2	5.00/10.00	0.003185	11.5
0.75	1.00	T80B-4 BR B5	1400	2.20	71	0.70	4.4	2.2	2.5	5.00/10.0	0.003445	12.7
1.10	1.50	T90S-4 BR B5	1410	2.80	75	0.78	4.6	2.2	2.4	10.00/20.0	0.004960	16.7
1.50	2.00	T90L-4 BR B5	1400	3.65	76	0.80	4.8	2.2	2.6	10.00/20.0	0.005190	19.5
2.20	3.00	T100LA-4 BR B5	1410	5.10	79	0.82	5.6	2.2	2.6	15.00/30.0	0.009830	25.0
3.00	4.00	T100LB-4 BR B5	1410	6.80	81	0.82	5.8	2.7	2.8	15.00/30.0	0.010990	28.9
4.00	5.50	T112M-4 BR B5	1420	8.70	82	0.83	6.0	2.7	2.9	20.00/40.0	0.016600	35.8
5.50	7.50	T132S-4 BR B5	1440	11.50	85	0.83	6.2	2.6	2.8	35.00/70.0	0.044300	-
7.50	10.20	T132M-4 BR B5	1445	15.50	86	0.83	6.7	2.7	3.0	35.00/70.0	0.051900	-
9.50	13.00	T132MA-4 BR B5	1430	18.90	88	0.83	6.0	2.9	3.0	35.00/70.0	0.053800	-
11.00	15.00	T160M-4 BR B5	1460	20.40	89	0.87	6.8	2.3	3.0	110	0.065500	-
15.00	20.40	T160L-4 BR B5	1460	27.50	90	0.87	7.5	2.5	3.1	150	0.089500	-

1000 min<sup>-1</sup> S1, S4 - 40% 240 h<sup>-1</sup>

0.12	0.16	T63B-6 BR B5	880	0.63	56	0.60	2.2	2.2	2.2	1.25	0.013200	7.2
0.18	0.25	T71A-6 BR B5	900	0.66	57	0.68	2.5	1.8	2.0	2.5/5.0	0.001540	8.5
0.25	0.34	T71B-6 BR B5	880	0.91	60	0.66	2.8	1.9	2.0	2.5/5.0	0.001690	9.0
0.37	0.50	T80A-6 BR B5	930	1.30	62	0.67	3.5	2.0	2.1	5.0/10	0.003845	11.5
0.55	0.75	T80B-6 BR B5	925	1.91	66	0.66	3.3	2.0	2.3	5.0/10	0.004115	12.5
0.75	1.00	T90S-6 BR B5	935	2.10	72	0.73	4.0	2.1	2.4	10.0/20	0.006150	17.3
1.10	1.50	T90L-6 BR B5	930	2.90	75	0.75	4.6	2.3	2.4	10.0/20	0.007330	20.8
1.50	2.00	T100L-6 BR B5	920	4.00	75	0.77	5.0	1.8	2.1	15.0/30	0.013880	25.9
2.20	3.00	T112M-6 BR B5	940	5.90	78	0.78	4.9	2.0	2.5	20.0/40	0.020400	34.3
3.00	4.00	T132S-6 BR B5	960	7.30	81	0.76	5.0	1.7	2.4	35.0/70	0.044700	-
4.00	5.50	T132MA-6 BR B5	960	9.70	83	0.73	6.0	2.3	2.8	35.0/70	0.051900	-
5.50	7.50	T132MB-6 BR B5	960	13.90	83	0.71	6.2	2.4	2.8	35.0/70	0.058300	-
7.50	10.20	T160M-6 BR B5	965	15.60	86	0.80	6.5	2.2	3.3	110	0.073150	-
11.0	15.00	T160L-6 BR B5	965	20.80	87	0.84	7.4	2.4	3.3	150	0.104500	-

Rated Output		Type	Rotation speed	Current	Efficiency	Power Factor	Starting characteristics			Brake moment	Moment of Inertia	Weight
							$I_S/I_R$	$M_S/M_R$	$M_{MAX}/M_R$			All alloy
Nennleistung		Typ	Nenn-drehzahl	Strom	Wirkungs-grad	Leis-tungs-Fac-tor	Als Vielfaches des			Brems-moment	Trägheits-moment	Gewicht
$P_2$		Indication	n	$I_R$	$\eta$	$\cos\phi$	$I_S/I_N$	$M_S/M_N$	$M_M/M_N$	Mbr	J	m
kW	HP		rpm	A	%					Nm	kg.m <sup>2</sup>	kg

750/3000 min<sup>-1</sup> S1, S4 - 20/40% 240 h<sup>-1</sup>

0.02/0.09	0.031/0.12	T63A-8/2 BR B5	670/2830	0.30/0.30	16/51	0.66/0.75	1.4/4.1	1.5/2.2	1.8/3.0	1.25	0.0006204	6.6
0.03/0.12	0.040/0.16	T63B-8/2 BR B5	650/2800	0.34/0.39	18/52	0.72/0.79	1.4/3.6	1.5/2.1	1.5/2.3	1.25	0.0006744	7.0
0.05/0.18	0.060/0.25	T71A-8/2 BR B5	660/2730	0.50/0.60	18/54	0.60/0.82	1.5/3.3	1.9/2.0	2.9/4.7	2.50	0.0012000	8.8
0.06/0.24	0.080/0.32	T71B-8/2 BR B5	710/2830	0.75/0.76	19/55	0.64/0.88	1.5/3.3	2.0/2.1	3.0/4.8	2.50	0.0013300	9.7
0.075/0.30	0.100/0.40	T80A-8/2 BR B5	720/2910	1.10/1.10	18/59	0.62/0.77	2.0/5.1	2.3/2.3	4.5/6.1	4.0	0.0031850	12.0
0.13/0.55	0.180/0.75	T80B-8/2 BR B5	720/2880	1.40/1.70	23/63	0.60/0.79	2.0/4.0	2.3/2.2	3.6/3.1	4.0	0.0034450	13.0
0.18/0.24	0.240/1.00	T90S-8/2 BR B5	700/2880	2.20/2.60	25/65	0.58/0.87	2.2/6.7	2.1/2.0	3.5/3.0	10.0	0.0035620	17.0
0.25/1.10	0.340/1.50	T90L-8/2 BR B5	720/2890	2.20/2.60	30/70	0.54/0.90	3.0/5.0	2.2/2.0	3.0/4.0	10.0	0.0051900	19.3
0.37/1.50	0.500/2.00	T100LA-8/2 BR B5	720/2880	2.70/3.20	33/78	0.60/0.90	2.0/5.0	1.9/2.0	3.0/3.0	20.0	0.0098300	25.0
0.55/2.20	0.750/3.00	T00LB-8/2 BR B5	720/2900	3.70/4.70	40/79	0.50/0.90	2.0/5.0	1.9/2.4	3.0/3.0	20.0	0.0109900	28.9
0.75/3.00	1.000/4.00	T112M-8/2 BR B5	730/2900	5.30/7.50	40/72	0.50/0.86	3.0/6.0	2.3/2.3	3.3/3.4	25.0	0.0166000	35.8

500/1500 min<sup>-1</sup> S1, S4 - 20/40% 240 h<sup>-1</sup>

0.05/0.15	0.08/0.20	T71A-12/4 BR B5	470/1440	0.93/0.69	11/55	0.70/0.72	1.2/3.2	1.90/1.80	2.3/2.4	2.5	0.001540	8.5
0.06/0.20	0.08/0.28	T71B-12/4 BR B5	470/1440	0.94/0.71	15/60	0.69/0.71	1.3/3.5	1.95/1.80	2.4/2.5	2.5	0.001700	8.5
0.08/0.25	0.11/0.34	T80A-12/4 BR B5	440/1450	1.30/1.30	14/43	0.68/0.71	1.2/2.8	2.10/2.10	2.7/3.3	4.9	0.003845	11.5
0.12/0.37	0.16/0.50	T80B-12/4 BR B5	440/1450	180/1.80	14/47	0.71/0.64	1.2/2.6	2.30/2.10	2.8/3.2	4.0	0.004115	12.5
0.18/0.55	0.24/0.75	T90S-12/4 BR B5	450/1420	2.10/1.60	16/66	0.71/0.78	1.3/4.2	1.80/1.95	2.2/2.7	10.0	0.006150	16.6
0.25/0.75	0.34/1.00	T90L-12/4 BR B5	450/1430	2.70/2.20	21/63	0.65/0.74	1.3/3.3	2.00/1.90	2.3/2.9	10.0	0.007330	26.5
0.37/1.10	0.50/1.50	T100LA-12/4 BR B5	440/1420	3.40/3.00	25/67	0.65/0.81	1.1/1.2	1.80/1.90	2.0/2.4	20.0	0.013880	26.0
0.55/1.50	0.75/2.00	T100LB-12/4 BR B5	430/1410	5.00/4.00	26/66	0.65/0.82	1.2/1.2	1.80/1.92	2.0/2.4	20.0	0.013880	29.0
0.75/2.20	1.00/3.00	T112M-12/4 BR B5	450/1400	6.50/6.00	33/70	0.54/0.82	1.3/1.3	1.80/1.90	2.1/2.5	25.0	0.020400	35.8
1.33/4.00	1.80/5.50	T132MA-12/4 BR B5	460/1450	7.70/8.90	48/80	0.56/0.83	1.5/4.0	1.90/2.00	2.3/2.6	35.0	0.051900	65.0
1.66/5.00	2.30/6.80	T132MB-12/4 BR B5	470/1450	9.10/11.00	49/81	0.57/0.84	1.6/5.0	1.90/2.10	2.3/2.6	35.0	0.058300	72.0

SMART digital monitoring

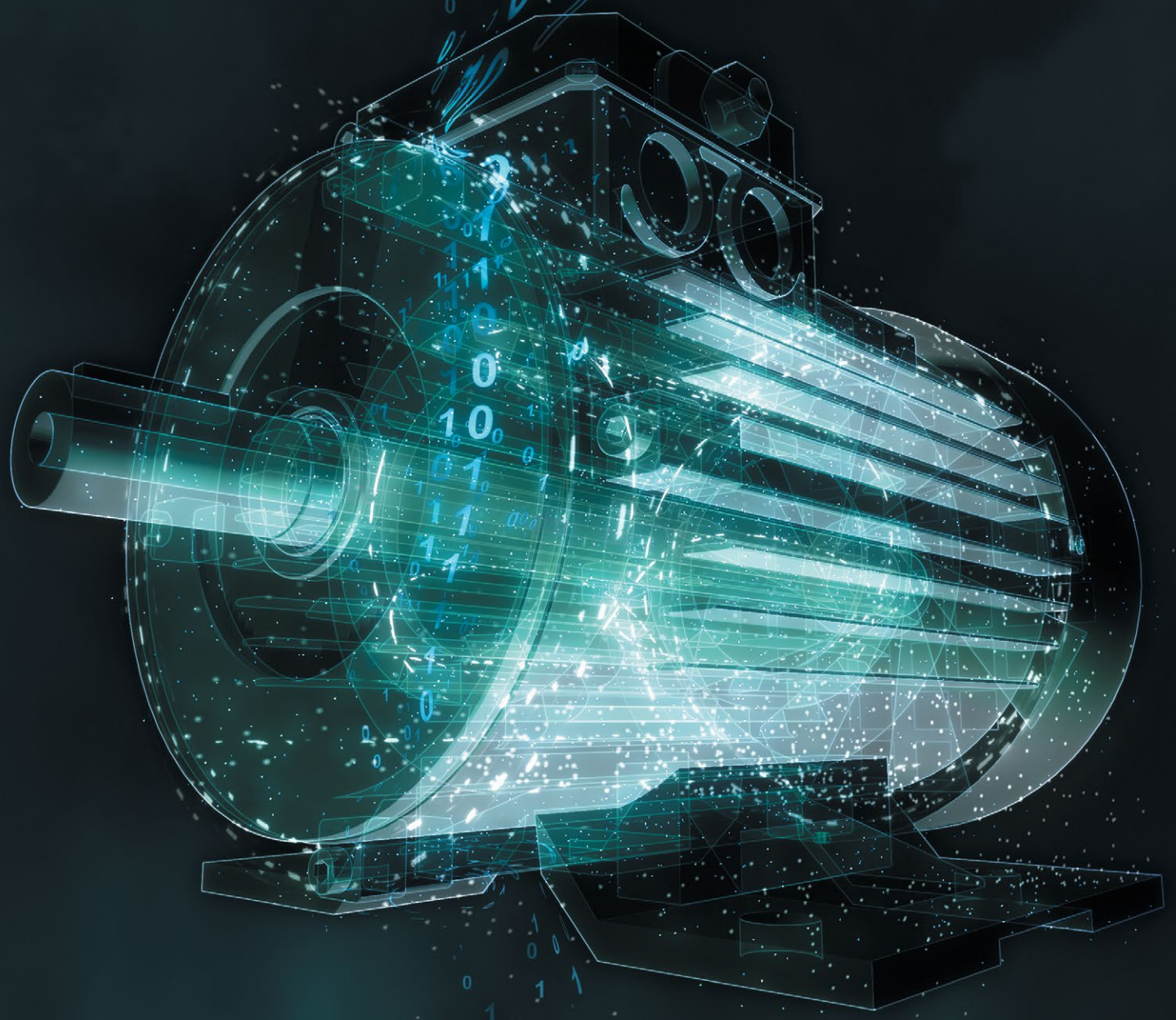

Industry 4.0

11



Digitalization

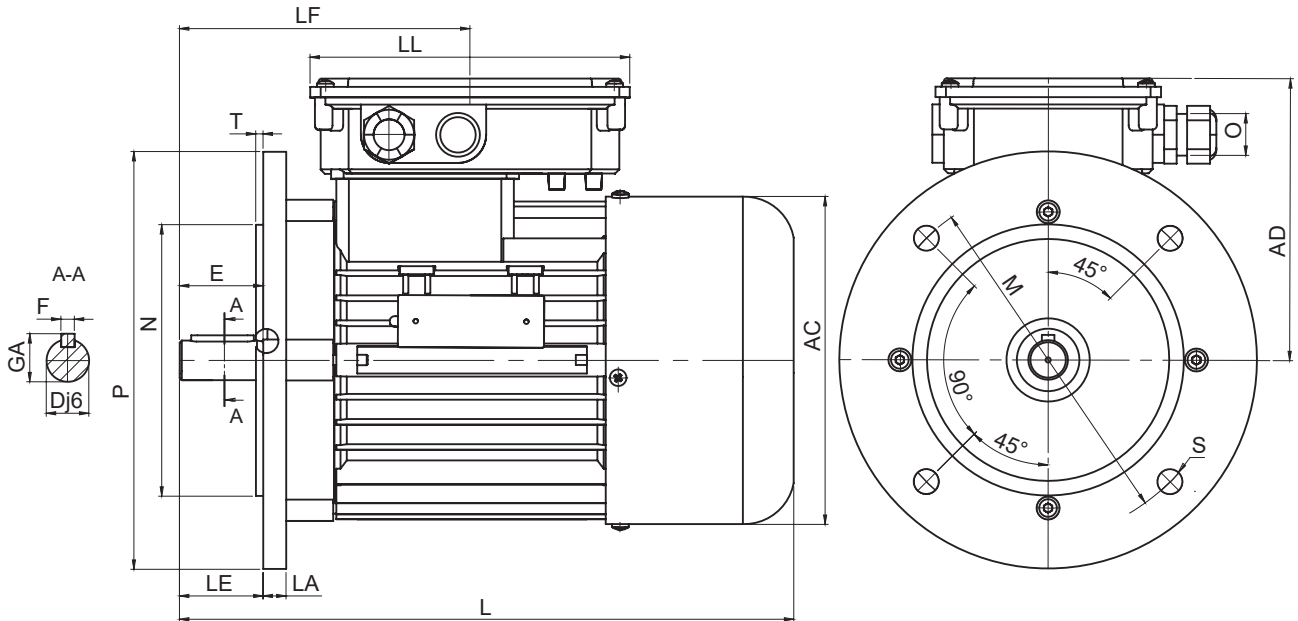

Type	Dimensions, mm																	
Typ	Abmessungen, mm																	
	Flange	AC	AD	D	E	F	GA	L	LA	LE	LF	LL	M	N	O	P	S	T
T63 BR	A140	123	117	11	23	4	12.5	242	10.5	23	37	134	115	95	M16	140	9	3
T71 BR	A140 A160	140	127	14	30	5	16	262	10	30	51		130	110		160		
T80 BR	A160 A200	157	136	19	40	6	21.5	295	11	40	62	153	165	130	M20	200	12	3.5
T90S BR	A160 A200	174	149	24	50	8	27	336		50	76		130	110		165	130	
T90L BR	A160 A200							130	110	160	9							
T100BR	A200 A250	192	150	28	60	31	406	15	60	92	215	180	M32	300	14	4		
T112 BR	A250	220	160														431	94
T132S BR	A300	257	188	38	80	10	41	512	20	80	125	206	265	230	350	19	5	
T132M BR								550										300
160M BR	A350	309	243	42	110	12	46	677	14	110	252	187	300	250	350	19	5	
T160L BR								721										

Rated Output	Type	Rotation speed	Current	Efficiency	Power Factor	$I_S/I_R$	$M_S/M_R$	$M_{MAX}/M_R$	Brake moment	Moment of Inertia	Weight
						Starting characteristics					All alloy
Nennleistung	Typ	Nenn-drehzahl	Strom	Wirkungs-grand	Leis-tungs-Fac-tor	$I_S/I_R$	$M_S/M_R$	$M_{MAX}/M_R$	Brems-moment	Trägheits-moment	Gewicht
						Als Vielfaches des					Aluminium
$P_2$	Indication	n	$I_R$	$\eta$	$\cos\phi$	$I_S/I_R$	$M_S/M_R$	$M_{MAX}/M_R$	Mbr	J	m
kW	HP	rpm	A	%					Nm	kg.m <sup>2</sup>	kg

1500 min<sup>-1</sup> S1, S4 - 40% 240 h<sup>-1</sup>

0.55	0.75	T80 A-4 BR-42	1400	1.62	69	0.74	3.7	1.8	2.2	4	0.003185	11.5
0.75	1.00	T80 B-4 BR-42	1400	2.20	71	0.70	4.4	2.2	2.5	4	0.003445	12.7

1000 min<sup>-1</sup> S1, S4 - 40% 240 h<sup>-1</sup>

0.37	0.50	T80 A-6 BR-42	905	1.45	60	0.64	2.4	2.0	2.4	4	0.003840	11.5
------	------	---------------	-----	------	----	------	-----	-----	-----	---	----------	------

750 min<sup>-1</sup> S1, S4 - 40% 240 h<sup>-1</sup>

0.25	0.34	T80 B-8 BR-42	700	1.25	53	0.56	2.4	2.0	2.3	4	0.004115	12.8
0.37	0.50	T90 S-8 BR-42	680	1.25	63	0.67	3.2	1.6	1.9	6	0.006150	18.00

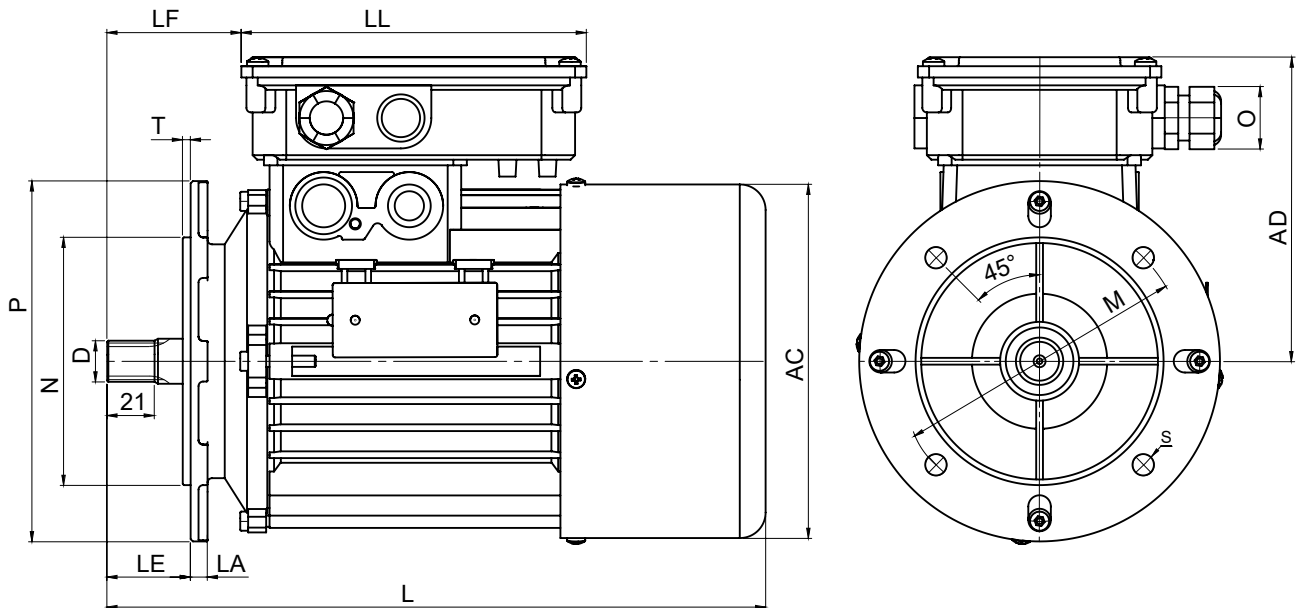

Type	Dimensions, mm														
Typ	Abmessungen, mm														
	Flange	AC	AD	D	L	LA	LE	LF	LL	M	N	O	P	S	T
T80-42	160	157	136	18x1.5x10	262	8	37	60	153	130	110	M20	160	9.5	3.5
T90S-42		174	149		295			62							3.5
T90L-42					336										3.5

Rated Output		Type	Rotation speed	Current	Efficiency	Power Factor	Starting characteristics			Brake moment	Moment of Inertia	Weight
							$I_s/I_R$	$M_s/M_R$	$M_{MAX}/M_R$			All alloy
Nennleistung		Typ	Nenn-drehzahl	Strom	Wirgungs-grand	Leis-tungs-Fac-tor	Als Vielfaches des			Brems-moment	Trägheitsmoment	Gewicht
$P_2$		Indication	n	$I_R$	$\eta$	$\cos\phi$	$I_s/I_R$	$M_s/M_R$	$M_{MAX}/M_R$	Mbr	J	m
kW	HP		rpm	A	%					Nm	kg.m <sup>2</sup>	kg

3000 min<sup>-1</sup> S1, S4 - 40% 240 h<sup>-1</sup>

0.18	0.25	KT63A-2	2770	0.51	64	0.81	3.6	2.3	2.5	1.25	0.000765	6.3
0.25	0.34	KT63B-2	2770	0.84	62	0.74	4.1	2.2	2.8	1.25	0.000812	6.8
0.37	0.50	KT71A-2	2800	0.95	71	0.83	4.3	2.2	2.4	2.50	0.000957	8.8
0.55	0.75	KT71B-2	2790	1.40	71	0.81	4.1	2.3	2.4	1.25	0.000976	9.3
0.75	1.00	KT80A-2	2820	2.00	72	0.82	5.0	2.4	2.6	4.00	0.002490	12.2
1.10	1.50	KT80B-2	2820	2.70	77	0.88	5.3	2.6	2.6	4.00	0.002590	13.3

1500 min<sup>-1</sup> S1, S4 - 40% 240 h<sup>-1</sup>

0.12	0.16	KT63A-4	1340	0.44	59	0.71	3.0	2.0	2.0	1.25	0.000801	6.6
0.18	0.25	KT63B-4	1360	0.81	51	0.66	3.0	2.0	2.3	1.25	0.000855	7.0
0.25	0.34	KT71A-4	1350	0.83	65	0.70	3.1	2.0	2.1	2.50	0.001215	8.8
0.37	0.50	KT71B-4	1350	1.18	66	0.72	3.2	2.1	2.2	1.25	0.001344	9.7
0.55	0.75	KT80A-4	1400	1.70	69	0.74	3.7	1.8	2.1	4.00	0.002870	12.0
0.75	1.00	KT80B-4	1400	2.30	71	0.70	4.4	2.2	2.5	4.00	0.003131	13.0
1.10	1.50	KT90S-4	1400	2.80	75	0.75	4.6	2.2	2.4	6.00	0.004165	16.9

1000 min<sup>-1</sup> S1, S4 - 40% 240 h<sup>-1</sup>

0.12	0.16	KT63B-6	880	0.63	56	0.60	2.2	2.2	2.2	1.25	0.00132	7.2
0.18	0.25	KT71A-6	880	0.70	57	0.68	2.5	1.8	2.0	2.50	0.00155	8.9
0.25	0.34	KT71B-6	910	0.90	60	0.70	2.8	2.0	2.2	2.50	0.00170	9.6
0.37	0.50	KT80A-6	905	1.45	60	0.64	2.4	2.0	2.4	4.00	0.00361	11.7
0.55	0.75	KT80B-6	925	2.00	66	0.66	3.3	2.0	2.2	4.00	0.00388	13.0

750-3000 min<sup>-1</sup> S1, S4 - 20/40% 240 h<sup>-1</sup>

0.023/0.09	0.031/0.12	KT63A-8/2	670/2830	0.30/0.30	16/51	0.66/0.75	1.4/4.1	1.5/2.2	1.8/3.0	0.4/0.4	0.000620	6.6
0.030/0.12	0.040/0.16	KT63B-8/2	650/2800	0.34/0.39	18/52	0.72/0.79	1.4/3.6	1.5/2.1	1.5/2.3	0.4/0.4	0.000674	7.0
0.045/0.18	0.060/0.25	KT71A-8/2	660/2730	0.50/0.60	18/54	0.60/0.82	1.5/3.3	1.9/2.0	2.2/4.7	0.8/0.8	0.001200	8.8
0.060/0.24	0.080/0.32	KT71B-8/2	710/2830	0.75/0.76	19/55	0.64/0.88	1.5/3.3	2.0/2.1	3.0/4.8	0.8/0.8	0.001330	9.7
0.075/0.30	0.100/0.40	KT80A-8/2	720/2910	1.10/1.10	18/59	0.62/0.77	2.0/5.1	2.3/2.3	4.5/6.1	4.0/4.0	0.003185	12.0
0.130/0.55	0.180/0.75	KT80B-8/2	720/2880	1.40/1.70	23/63	0.60/0.79	2.0/4.0	2.3/2.2	3.6/3.1	4.0/4.0	0.003445	13.0
0.180/0.24	0.240/1.00	KT90S-8/2	700/2800	1.80/2.00	25/65	0.58/0.87	2.2/6.7	2.1/2.0	2.5/3.0	6.0/6.0	0.003562	17.0

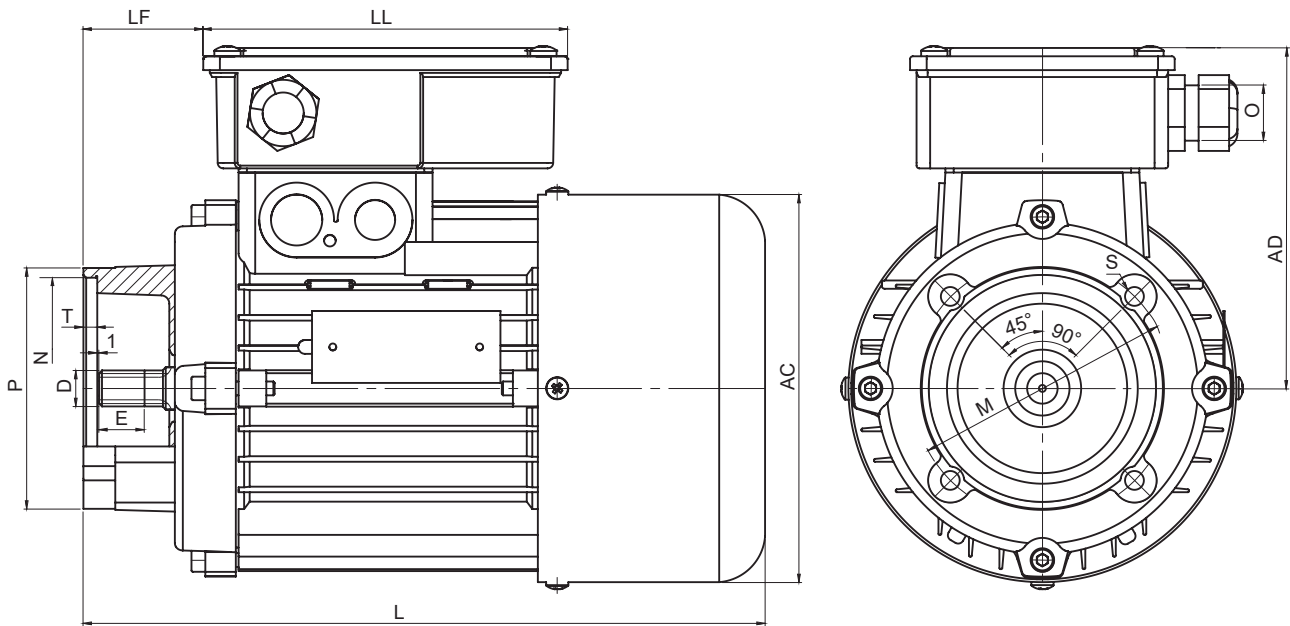

Type	Dimensions, mm												
Typ	Abmessungen, mm												
	AC	AD	D	E	L	LF	LL	M	N	O	P	S	T
KT63	123	117	13x12x1	13	250	44	134	94	80	M20	87	M8	5
KT71	140	127			255								
KT80	157	136			280	50							
KT90S	174	138			315	53	153						

Rated Output		Type	Rotation speed	Current	Efficiency	Power Factor	$I_s/I_R$	$M_s/M_R$	$M_{MAX}/M_R$	Brake moment	Moment of Inertia	Weight
							Starting characteristics					All alloy
Nennleistung		Typ	Nenn-drehzahl	Strom	Wirkungs-grad	Leis-tungs-Fac-tor	$I_s/I_R$	$M_s/M_R$	$M_{MAX}/M_R$	Brems-moment	Trägheits-moment	Gewicht
							Als Vielfaches des					Alumin-ium
P <sub>2</sub>		Indication	n	I <sub>R</sub>	η	cosφ	$I_s/I_R$	$M_s/M_R$	$M_{MAX}/M_R$	Mbr	J	m
kW	HP		rpm	A	%					Nm	kg.m <sup>2</sup>	kg

1500 min<sup>-1</sup> S1, S4 - 40% 240 h<sup>-1</sup>

0.18	0.24	KT63B-4-35	1360	0.81	51	0.66	3.0	2.0	2.3	1.25	0.000855	8.0
0.37	0.50	KT71B-4-35	1350	1.18	66	0.72	3.2	2.1	2.2	2.50	0.001344	10.5
0.55	0.75	KT80A-4-35	1400	1.70	69	0.74	3.7	1.8	2.1	4.00	0.002870	15.5
0.75	1.00	KT80B-4-35	1400	2.30	71	0.70	4.4	2.2	2.5	4.00	0.003131	13.0

1000 min<sup>-1</sup> S1, S4 - 40% 240 h<sup>-1</sup>

0.12	0.16	KT63B-8-35	880	0.63	56	0.60	2.2	2.2	2.2	1.25	0.000855	8.5
0.25	0.34	KT71B-8-35	910	0.90	60	0.70	2.8	2.0	2.2	2.50	0.001700	10.5
0.37	0.50	KT80A-8-35	905	1.45	80	0.84	3.4	2.4	2.4	4.00	0.003610	12.5
0.75	1.00	KT90S-8-35	935	2.10	72	0.73	4.0	2.1	2.4	6.00	0.006150	17.5

500-1500 min<sup>-1</sup> S1, S4 - 20/40% 240 h<sup>-1</sup>

0.8/0.25	0.11/0.34	KT80A-12/4-35	440/1450	1.4/1.4	12/45	0.72/0.65	1.2/2.8	2.1/2.1	2.8/2.6	4.0	0.00361	12.5
0.12/0.37	0.16/0.50	KT80B-12/4-35	450/1440	1.9/1.9	14/47	0.71/0.66	1.1/2.5	2.3/2.1	2.8/3.2	4.0	0.00388	13.5
0.25/0.75	0.34/1.00	KT90L-12/4-35	450/1440	2.8/2.4	22/64	0.65/0.74	1.2/3.3	2.1/2.0	2.3/2.9	6.0	0.00475	20.5

500-1000 min<sup>-1</sup> S1, S4 - 20/40% 240 h<sup>-1</sup>

0.60/0.12	0.80/0.16	KT71B-12/6-35	460/960	0.96/0.75	15/40	0.69/0.61	1.2/2.2	2.2/1.9	2.5/2.5	2.5	0.00354	10.1
0.12/0.25	0.16/0.34	KT80B-12/6-35	430/930	1.8/1.7	16/42	0.73/0.66	1.2/2.0	2.5/2.3	2.5/2.8	4.0	0.03875	14.5
0.18/0.37	0.24/0.50	KT90S-12/6-35	460/970	2.0/2.0	19/49	0.61/0.57	1.2/2.8	2.0/2.0	2.3/3.4	6.0	0.00396	16.0
0.25/0.55	0.34/0.73	KT90L-12/6-35	450/970	2.5/2.6	21/51	0.61/0.57	1.3/2.0	2.0/2.1	2.3/3.5	6.0	0.00484	18.0

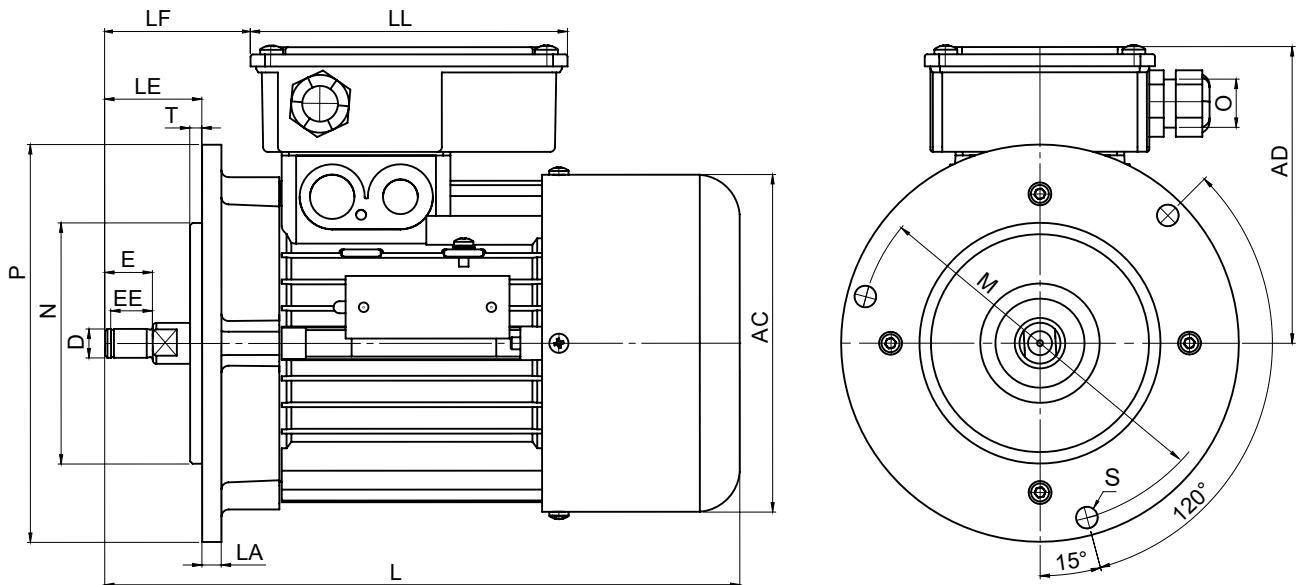

Type	Dimensions, mm																
Typ	Abmessungen, mm																
	AC	AD	D	E	EE	L	LA	LE	LF	LL	M	N	O	P	S	T	
KT63B 4,6-35	123	117	10	20	17.3	257	8	30	51	134	120	60	M20	135	7	6	
KT71B 4,6,12/6-35	140	127	12			272		36			150			100	165	9	5
KT80A,B 4,6-35		136				290		120	60	135	7	6					
KT80A 12/4-35	157	124	10	20	17.3	314	10	30	60	153	120	60	M20	135	7	6	
KT80B 12/4,12/6-35		138				290	8							150	100	165	9
KT90S 6,12/6-35			12			327	11	36				150		100	165	9	5
KT90L 12/4,12/6-35	174	149				352											

Rated Output	Type	Rotation speed	Current	Efficiency	Power Factor	$I_S/I_R$	$M_S/M_R$	$M_{MAX}/M_R$	Brake moment	Moment of Inertia	Weight
						Starting characteristics					All alloy
Nennleistung	Typ	Nenn-drehzahl	Strom	Wirkungs-grad	Leis-tungs-Fac-tor	$I_S/I_R$	$M_S/M_R$	$M_{MAX}/M_R$	Brems-moment	Trägheits-moment	Gewicht
						Als Vielfaches des					Aluminium
$P_2$	Indication	n	$I_R$	$\eta$	$\cos\phi$	$I_S/I_R$	$M_S/M_R$	$M_{MAX}/M_R$	Mbr	J	m
kW	HP	rpm	A	%					Nm	kg.m <sup>2</sup>	kg

3000 min<sup>-1</sup> S1, S4 - 40% 240 h<sup>-1</sup>

0.37	0.50	KT71A-2-53	2900	0.95	71	0.83	4.3	2.2	2.4	2.5	0.000957	8.8
0.55	0.75	KT71B-2-53	2790	1.40	71	0.81	4.1	2.3	2.4	2.5	0.000976	9.3
0.75	1.00	KT80B-2-53	2820	2.00	72	0.82	5.0	2.4	2.6	4.0	0.002490	12.2

1500 min<sup>-1</sup> S1, S4 - 40% 240 h<sup>-1</sup>

0.25	0.34	KT71A-4-53	1350	0.83	65	0.7	3.1	2.0	2.1	2.5	0.001213	8.8
------	------	------------	------	------	----	-----	-----	-----	-----	-----	----------	-----

750-3000 min<sup>-1</sup> S1, S4 - 40% 240 h<sup>-1</sup>

0.13/0.55	0.18/0.75	KT80B-8/2-53	720/2880	1.4/1.7	23/63	0.6/0.79	2.2/4.0	2.1/1.7	3.6	4.0	0.003445	13.0
-----------	-----------	--------------	----------	---------	-------	----------	---------	---------	-----	-----	----------	------

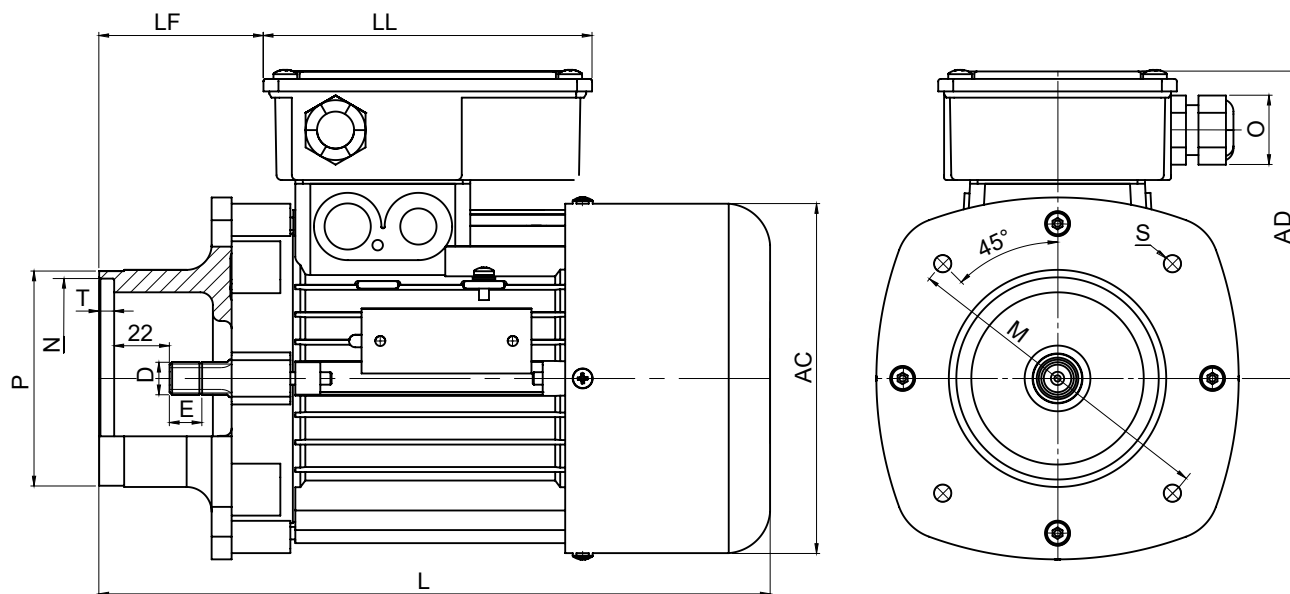

Type	Dimensions, mm												
Typ	Abmessungen, mm												
	AC	AD	D	E	L	LF	LL	M	N	O	P	S	T
KT71-53	140	127	13x12x1	13	269	66	134	130	80	M20	87	M6	6
KT80-53	157	136			296		153						

Rated Output		Type	Rotation speed	Current	Efficiency	Power Factor	Starting characteristics			Brake moment	Moment of Inertia	Weight
							$I_s/I_R$	$M_s/M_R$	$M_{MAX}/M_R$			All alloy
Nennleistung		Typ	Nenn-drehzahl	Strom	Wir-kungs-grand	Leis-tungs-Fac-tor	Als Vielfaches des			Brems-moment	Trägheitsmoment	Gewicht
							$I_s/I_R$	$M_s/M_R$	$M_{MAX}/M_R$			Aluminium
$P_2$		Indication	n	$I_R$	$\eta$	$\cos\phi$	$I_s/I_R$	$M_s/M_R$	$M_{MAX}/M_R$	Mbr	J	m
kW	HP		rpm	A	%					Nm	kg.m <sup>2</sup>	kg

1500 min<sup>-1</sup> S1, S4 - 40% 240 h<sup>-1</sup>

1.5	2.0	CT90L-4 K	1400	3.65	76	0.80	4.8	2.2	2.6	20	0.00519	26
2.2	3.0	CT100LA-4 K	1410	5.13	81	0.82	5.6	2.2	2.6	30	0.00983	37.5
5.5	7.5	CT132S-4 K	1440	11.0	86	0.83	6.2	2.6	2.8	70	0.04430	69
7.5	10.2	CT132M-4 K	1445	16.3	85	0.83	6.7	2.7	3.0	70	0.05190	89
9.5	13.0	CT132MA-4 K	1430	15.5	88	0.83	6.0	2.9	3.0	100	0.05210	82

1000 min<sup>-1</sup> S1, S4 - 40% 240 h<sup>-1</sup>

1.5	2.0	CT100L-6 K	920	4.00	75	0.77	5.0	1.8	2.1	30	0.01388	38.5
3.0	4.0	CT132S-6 K	960	7.32	81	0.76	5.0	1.7	2.4	70	0.04470	69
5.0	6.8	CT132M-6 K	955	12.80	82	0.70	6.2	2.5	2.8	70	0.05370	82
7.5	10.2	CT160M-6 K	960	15.60	86	0.80	6.5	2.2	3.3	110	0.07315	120

500-1500 min<sup>-1</sup> S1, S4 - 20/40% 240 h<sup>-1</sup>

0.37/0.10	0.50/1.50	CT100LA-12/4 K	450/1420	3.04/2.85	78/75	0.63/0.83	2.2/4.5	1.7/1.8	2.0/2.4	20	0.013880	38.5
0.55/1.50	0.75/2.00	CT100LB-12/4 K	430/1390	3.80/3.80	78/78	0.61/0.87	1.9/4.2	2.0/1.9	1.9/2.3	30	0.015166	41
0.75/1.00	2.20/3.00	CT112M-12/4 K	450/1400	6.50/6.00	33/70	0.54/0.85	1.3/1.3	1.8/1.9	2.1/2.5	40	0.020400	35.8
1.33/4.0	1.8/5.5	CT132MA-12/4 K	450/1410	8.0/10.0	20/40	0.73/0.83	1.5/4.0	1.9/2.0	2.3/2.6	35/70	0.051900	66
1.65/5.0	2.3/6.8	CT132MB-12/4 K	460/1430	10.2/11.4	20/40	0.73/0.83	1.6/5.0	1.9/2.1	2.3/2.6	35/70	0.058300	75
2.70/8.5	3.50/11.3	CT160M-12/4 K	480/1460	14.00/16.00	66/86	0.47/0.82	1.5/5.0	2.2/2.1	2.2/2.8	110	0.058465	120

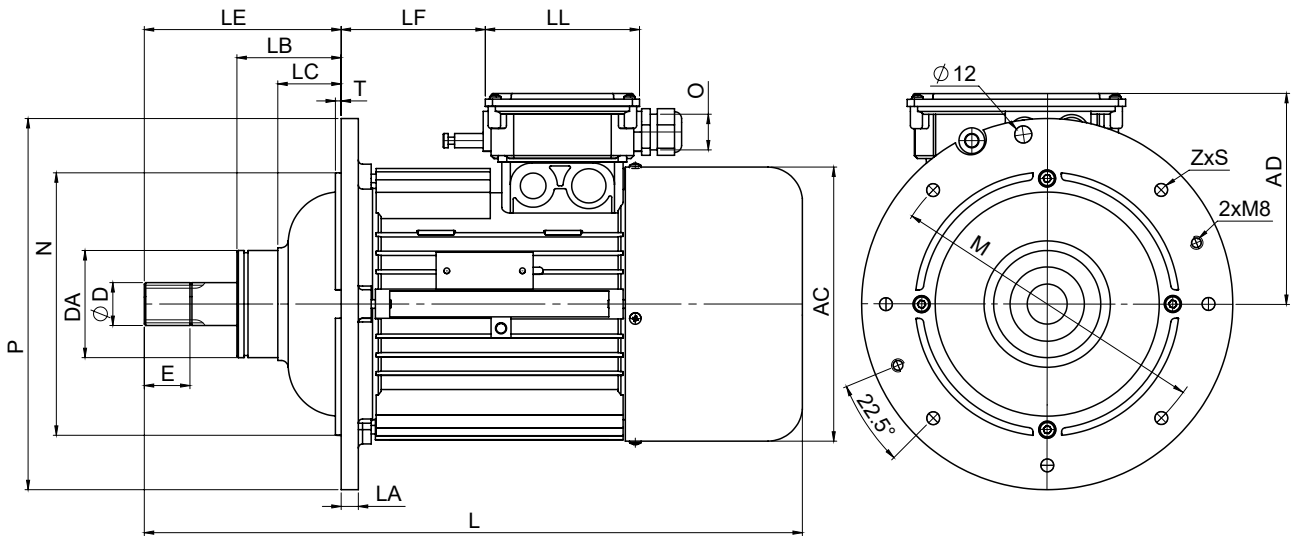

Type	Dimensions, mm																	
Typ	Abmessungen, mm																	
	AC	AD	D	DA	E	L	LA	LB	LC	LE	LF	LL	M	N	O	P	ZxS	T
CT90L	174	132	E <sub>25</sub> x1.5x9g	75	27	437	14	73	44.4	125	84	136	226	185	M25	260	8x10	4
CT100	192	199				449	12				101							
CT112	220	152				474	118											
CT132 S	257	228	E <sub>30</sub> x1.5x9g	80	32	532	15	81	51.5	140	99	312	262	M32	345	7x11	5	
CT132 M						598				137								
CT132 MA4						667				144								
CT160 M6	310	283	E <sub>40</sub> x2x9g	75	38	672	17	110	75	146	156	380	325	M32	418	7x13		
CT160 M12/4			E <sub>30</sub> x1.5x9g			80											32	721

Rated Output		Type	Rotation speed	Current	Efficiency	Power Factor	$I_s/I_R$	$M_s/M_R$	$M_{MAX}/M_R$	Brake moment	Moment of Inertia	Weight
						Starting characteristics						All alloy
Nennleistung		Typ	Nenn-drehzahl	Strom	Wirkungs-grad	Leis-tungs-Fac-tor	$I_s/I_R$	$M_s/M_R$	$M_{MAX}/M_R$	Brems-moment	Trägheits-moment	Gewicht
							Als Vielfaches des					
$P_2$		Indication	n	$I_R$	$\eta$	cos $\phi$	$I_s/I_R$	$M_s/M_R$	$M_{MAX}/M_R$	Mbr	J	m
kW	HP		rpm	A	%					Nm	kg.m <sup>2</sup>	kg

1500 min<sup>-1</sup> S1, S4 - 40% 240 h<sup>-1</sup>

2.5	4.0	CT100LA-4 240	1410	5.4	79	0.82	5.6	2.2	2.6	30	0.00983	25
4.0	5.5	CT112M-4 240	1420	9.1	82	0.83	6.0	2.7	2.9	40	0.0166	35.8
6.0	8.0	CT132S-4 240	1430	13.8	85	0.83	6.2	2.6	3.0	70	0.03265	64
8.5	11.3	CT132M-4 240, 290	1440	17.0	86	0.83	6.7	2.7	3.0	70/110	0.0519/0.05623	66/70
10	13.3	CT132MA-4 240, 290	1440	18.1	88	0.83	6.0	2.9	3.0	70/110	0.05216/0.05841	82/87
12	16	CT160M-4 290	1460	25.0	88.4	0.84	2.2	7.0	2.3	150	0.05936	106
12	16	CT160M-4 360	1460	25.0	88.4	0.84	2.2	7.0	2.3	150	0.05948	109

1500 min<sup>-1</sup> S1, S4 - 20/40% 240 h<sup>-1</sup>

0.55/1.5	0.75/2.0	CT100LB-12/4 240	430/1410	5.0/4.0	26/66	0.65/0.82	1.2/1.2	1.8/1.92	2.0/2.4	30	0.01388	29
0.83/2.5	1.13/3.4	CT112M-12/4 240	450/1400	6.5/6.0	33/70	0.54/0.85	1.3/1.3	1.8/1.9	2.1/2.5	40	0.0204	35.8
1.33/4.0	1.8/5.5	CT132MA-12/4 240	460/1450	7.7/8.9	48/80	0.56/0.83	1.5/4.0	1.9/2.0	2.3/2.6	70	0.0519	65
1.66/5.0	2.3/6.8	CT132MB-12/4 240/5	470/1450	9.1/11.0	49/81	0.57/0.84	1.6/5.0	1.9/2.1	2.3/2.6	70	0.0583	72
2.0/6.0	2.7/8.2	CT132MB-12/4 240/6	440/1400	10.0/13.0	50/82	0.58/0.85	1.7/6.0	1.9/2.2	2.3/2.6	70	0.0583	72
2.7/8.5	3.3/11.3	CT160M-12/4 290	480/1460	14/18	66/86	0.47/0.82	1.5/5.0	2.0/2.1	2.2/2.8	110	0.0586	109
4.0/12.0	5.5/16.0	CT160L-12/4 290	470/1450	18/29	68/87	0.48/0.73	1.6/5.1	1.9/2.0	2.3/2.8	150	0.05885	140
4.0/12.0	5.5/16.0	CT160L-12/4 360	470/1450	18/29	68/87	0.48/0.73	1.6/5.1	1.9/2.0	2.3/2.8	150	0.05885	140

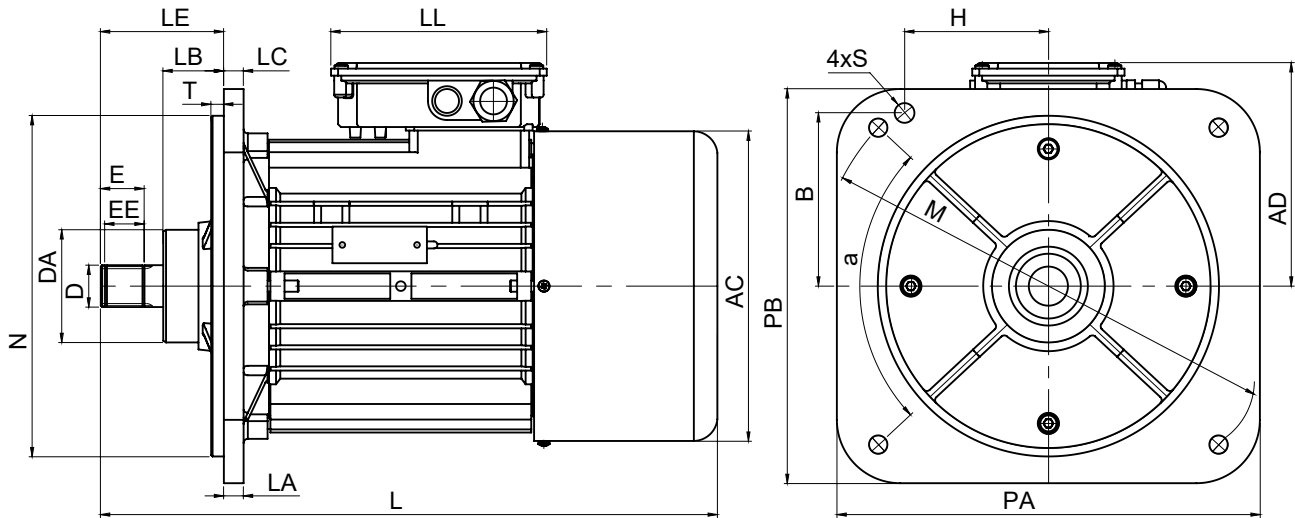

Type	Dimensions, mm																						
	Abmessungen, mm																						
Typ	AC	AD	B	H	D	DA	E	EE	L	LA	LB	LC	LE	LL	M	N	O	PA	PB	S	T	$\alpha$	
CT100-4 240	192	140	101		30x 1.25 x9g	80	31	28	404	14	43	18	80	153	330	242	300	280	13	9	86	86	
CT112M-4 240	220	160	123	102					434														M25
CT112M 12/4 240			101	101					434														
CT132 S-4 240	257	195	123	102	40x 1.25 x9g	105	34	29	494	16	47	18	90	206	370	292	M32	342	15	10	90		
CT132 M-4 240									532														
CT132 M4 240 KT7									556														
CT132 MA 12/4 240/5									532														
CT132 MB 12/4 240/6																							
CT132 M-4 290									529				90										
CT132 M-4 290 KT7									553														
CT160M-4 290	309	241	150	124	40x 1.25 x9g	105	34	29	658	16	47	18	93	171	370	292	M32	342	15	10	90		
CT160M 12/4 290									702														
CT160L 12/4 290									702														
CT160 M 12/4 360									681														
CT160L 12/4 360					45x2 x9g	120	35.8	31.6	725	18	57	22	114	440	362		410	19	12				

## Single-phase induction electric motors

The single-phase electric motors are provided with starting and running capacitors, and single-phase electric motor with running capacitor. Height of axis of rotation in mm;

**Single-phase with starting and running capacitor** - 80, 90, 100;

**Single-phase with running capacitor** - 63, 71, 80, 90, 100;

**Power** - 0.120 kW up to 3 kW depending on the poles;

**Pole:** 2, 4;

**Synchronous revolutions min<sup>-1</sup>:** 3000, 1500;

**Rated voltage and frequency** - 220 V up to 240 V, 50 Hz frequency;

**Duty cycle** - S1, S2, S3, S4, S6;

**Types of mounting** - B3, B5, B14, B3/B5(B35), B3/B14(B34);

**The adjusted flange can be of special type, as per customer's request.**

**Driving shaft end** - Cylindrical with a key, with or without inner thread, special, gear-cut, with two driving ends, as well as other varieties.

**Degree of protection** - IP54, IP55;

**Class of insulation** - standard F, could be also H - as per request;

**Ambient temperature** - moderate climate zone "n" at temperature -25° C up to +40° C;

**Attitude** - 1000 m;

### Power

Rated power of the motor shaft is defined under following conditions: Rated voltage, assigned on the plate at tolerance ±10%;

Frequency of the supply voltage at tolerance ±1%; **Ambient temperature** - -25° C up to +40° C;

**Altitude** - up to 1000 m;

**Duty cycle S1** - continuous, EN 60034-1;

At deviation of the indicated conditions, the admissible power of the shafts is defined by formula:

$$P_d = K_t \cdot K_h \cdot P_n$$

where:

**P<sub>d</sub>** - is the admissible power of shaft

**K<sub>t</sub>** - is the corrective coefficient, pointing the influence of the ambient temperature

**K<sub>h</sub>** - is the corrective coefficient, pointing the influence of the altitude

**P<sub>n</sub>** - is the rated power, pointed on the plate

See table 1 and 2 for the corrective coefficients

Table 1: Corrective coefficient, pointing the influence of the ambient temperature

t° [°C]	40	45	50	55	60
K <sub>t</sub> [-]	1	0.95	0.90	0.83	0.76

Table 2: Corrective coefficient, pointing the influence of the altitude

h[m]	1000	1500	2000	2500	3000	4000
K <sub>h</sub> [-]	1	0.98	0.95	0.91	0.87	0.78

Torque

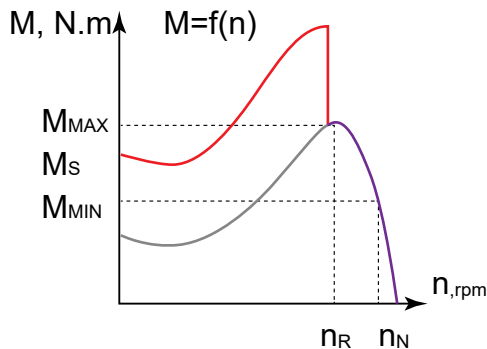

The rated torque at the output end of the electric motor is calculated by the dependence of

$$M = (9.55 \cdot P) / n$$

where

**M** [N.m] - rated torque

**P** [W] - rated power

**n** [min<sup>-1</sup>] - rated rotation speed

**M<sub>s</sub>** - starting torque

**M<sub>min</sub>** - minimum torque

**M<sub>max</sub>** - maximum torque

### Single-phase asynchronous electric motors with starting and running capacitor

That type of electric motors are provided with running capacitor which is permanently connected, and with starting capacitor, which is connected only at starting the electric motor for reaching high starting torque, and it is disconnected when the rotor of the electric motor reaches of about 70% speed of the rated speed of rotation.

As the electric motors with running and starting capacitors have high starting torque with multiplicity 1.6 up to 2.2 of the rated torque, they are suitable for drives where higher resistance torque should be overcome, like compressors, circular saws, pumps.

### Single-phase asynchronous electric motors with running capacitor

That type of electric motors have permanently connected capacitor, but the starting torque is low with multiplicity 0.3 up to 0.4 of the rated torque. They are suitable for application in drives with low resistance torque, for example in fans or similar mechanisms with fans.

### Single-phase asynchronous electric motors with running capacitor with increased starting torque

The special characteristic about them is that they have higher torque than the one of the single-phase electric motors with running capacitor, and lower than motors with starting and running capacitor. Their starting torque is with multiplicity 0.5 up to 0.7 of the rated torque.

## Einphasen - Asynchronelektromotoren

Die hergestellten Einphasen - Asynchronelektromotoren sind mit Anlass - und Betriebskondensator und Einphasen- Asynchronelektromotoren mit Betriebskondensator

**Drehachshöhe in mm:** Einphasen- Asynchronelektromotoren mit Anlass- und Betriebskondensator - 80, 90, 100;

Einphasen- Asynchronelektromotoren mit Betriebskondensator - 63, 71,80,90,100;

**Leistung** - von 0.120 kW bis 3 kW in Abhängigkeit von den Polen;

**Polen:** 2, 4;

**Synchrone Drehzahl min<sup>-1</sup>:** 3000, 1500;

**Nennspannung und Frequenz** - 220V bis 240V und Frequenz 50 Hz and 60 Hz;

**Betrieb** - S1, S2, S3, S4, S6;

**Bauformen** - B3, B5, B14, B3/B5(B35), B3/B14(B34);

**Nach Wunsch des Kunden kann der Vereinigungsflansch speziell sein Arbeitswellenende** - zylindrisch mit Passfeder, ohne oder mit Innengewinde, spwziel, verzahnt, profiliert mit zwei Arbeitsenden, sowie andere Variationen;

**Schutzart** - IP54, IP55;

**Isolierstoffklasse** - standart F, nach Anfrage kann auch H

**Betriebsbedingungen** - gemäßigtes Klimagebiet "n" bei Temperaturen von -25° C up to +40° C und **Aufstellungshöhe** bis 1000 m über NN

### Leistung

Die Nennleistung der Motorwelle wird bei den folgenden Bedingungen bestimmt: Nennspannung, gezeigt auf der Tabelle bei Toleranz ±10%;

Frequenze der Speisespannung bei Toleranz ±1%;

**Umwelttemperatur** - von -25° C bis +40° C;

**Meershöhe** bis 1000 m;

**Betrieb** - S1 dauernd EN 60034-1;

Bei Abweichungen von den angegebenen Bedingungen wird die zulässige Spannung der Motorwelle nach der Formel bestimmt:

$$P_d = K_t \cdot K_h \cdot P_n$$

wo:

**P<sub>d</sub>** - die zulässige Spannung der Motorwelle

**K<sub>t</sub>** - Korrekturkoeffizient, der den Einfluss der Umwelttemperatur abliest

**K<sub>h</sub>** - Korrekturkoeffizient, der den Einfluss der Meereshöhe abliest

**P<sub>n</sub>** - Nennleistung der Motorwelle, bezeichnet auf der tabelle

Die Korrekturkoeffizienten werden von Tabellen 1 und 2 abgelesen

Tabelle 1: Korrekturkoeffizient, der den Einfluss der Umwelttemperatur abliest

t° [°C]	40	45	50	55	60
K <sub>t</sub> [-]	1	0.95	0.90	0.83	0.78

Tabelle 2: Korrekturkoeffizient, der den Einfluss der Meereshöhe abliest

h[m]	1000	1500	2000	2500	3000	4000
K <sub>h</sub> [-]	1	0.98	0.95	0.91	0.87	0.78

### Drehmoment

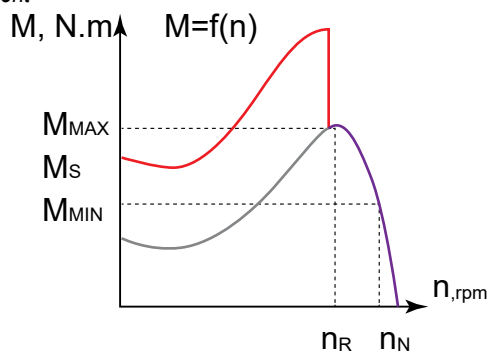

Der Nenndrehmoment am Ausgangsendes des Elektromotors wird nach der Formel gerechnet

$$M = (9,55 \cdot P) / n$$

wo

**M [N.m]** - Nenndrehmoment

**P [W]** - Nennspannung

**n [min<sup>-1</sup>]** - Nenngeschwindigkeit der Drehung

**M<sub>s</sub>** - Anlaufmoment

**M<sub>min</sub>** - Minimalmoment

**M<sub>max</sub>** - Höchstmoment

### Einphasen - Asynchronelektromotoren mit Anlass- und Betriebskondensator

Bei diesen Elektromotoren ist der Betriebskondensator ständig eingerückt, und der Anlaufkondensator ist nur beim Anlauf des Elektromotors eingerückt, mit Ziel einen großen Anlaufmoment zu erreichen und wird ausgeschaltet, wenn das Rotor des Elektromotors eine Geschwindigkeit ca. 70% von der Nenngeschwindigkeit der Drehung erreicht. Weil die Elektromotoren mit Anlass- und Betriebskondensator einen hohen Anlaufmoment besitzen, mit Multiplizität von 1.6 bis 2.2 des Nominellmoments, sind sie für Antriebe passend, wo größere Widerstandsmomente zu überwinden werden müssen, wie Kompressoren, Kreissägen, Pumpen.

### Einphasen - Asynchronelektromotoren mit Betriebskondensator

Bei diesen Elektromotoren ist der Kondensator ständig eingerückt, und der Anlaufmoment ist klein, und ist mit Multiplizität von 0.3 bis 0.4 vom Nominellmoment. Sie sind passend für Antriebe mit kleineren Widerstandsmomenten, wie Lüften oder ähnliche Mechanismen mit Lüftercharakteristik.

### Einphasen - Asynchronelektromotoren mit Betriebskondensator mit erhöhtem Anlaufmoment

Das Besondere bei diesen Elektromotoren ist, dass sie mit einem größeren Anlaufmoment sind, als dieser der Einphasen- Asynchronelektromotoren mit Betriebskondensator und mit kleinerem als dieser mit Anlauf- und Betriebskondensator. Ihr Anlaufmoment ist mit Multiplizität von 0.5 bis 0.7 vom Nominellmoment.

Rated Output		Type	Parameters at Rated Output				Starting characteristics			Capacitors - Capacitance at Voltage	Torque of Inertia	Weight	
			Rotation speed	Current	Efficiency	Power Factor	Current	Torque				Runing	Cast Iron
								$I_s/I_R$	$M_s/M_R$	$M_{MAX}/M_R$	DB		
kW	HP	Indication	rpm	A	%				$\mu F/V$	kg.m <sup>2</sup>	kg		

3000 rpm

0.18	0.25	ER63B-2	2780	1.43	60	0.91	2.9	0.46	1.7	6/400	0.000188	-	3.7
0.25	0.34	ER63C-2	2800	1.90	60	0.95	2.9	0.40	1.7	8/400	0.000244	-	4.1
0.37	0.50	ER71B-2	2840	2.70	67	0.90	3.4	0.40	2.0	10/450	0.000352	-	5.7
0.55	0.75	ER71C-2	2820	3.92	68	0.90	3.4	0.32	1.9	12/450	0.000404	-	6.2
0.75	1.00	ER80B-2	2890	4.40	78	0.95	4.5	0.35	2.1	20/400	0.000960	-	9.3
1.10	1.50	ER80C-2	2860	6.90	72	0.97	4.3	0.34	1.9	30/400	0.001000	-	10.6
1.50	2.00	ER90S-2	2880	9.30	76	0.92	5.0	0.30	2.1	35/400	0.001820	20.5	15.2
2.20	3.00	ER90L-2	2870	13.80	76	0.91	4.8	0.30	2.0	45/400	0.002220	22.6	17.3
3.0	4.00	ER100LB-2	2890	17.7	75	0.98	4.4	0.30	1.9	60/400	0.005550	-	22.0

3000 rpm

0.75	1.0	ERR80B-2	2850	5.1	73	0.95	4.3	0.60	2.4	30/400	0.001000	-	9.8
1.1	1.5	ERR80C-2	2830	7.0	74	0.94	4.0	0.60	2.1	40/400	0.001010	-	10.6
1.5	2.0	ERR90S-2	2810	9.7	72	0.94	4.2	0.65	2.3	50/400	0.001720	-	16.5
2.2	3.0	ERR90L-2	2800	13.9	73	0.94	3.9	0.60	2.1	60/400	0.002750	-	19.5

1500 rpm

0.12	0.16	ER63B-4	1380	1.20	52	0.86	2.3	0.65	1.7	6/400	0.000155	-	4.0
0.18	0.25	ER63C-4	1350	1.48	57	0.93	2.1	0.60	1.4	8/400	0.000221	-	4.3
0.25	0.34	ER71B-4	1400	1.90	63	0.90	3.0	0.55	1.7	10/450	0.000720	-	6.2
0.37	0.50	ER71C-4	1410	3.00	64	0.84	3.1	0.50	1.8	12/450	0.000930	-	7.1
0.55	0.75	ER80B-4	1420	4.00	66	0.90	3.5	0.37	1.7	16/400	0.001530	-	9.3
0.75	1.00	ER80C-4	1410	5.50	66	0.91	3.5	0.33	1.6	20/400	0.001670	-	9.9
1.10	1.50	ER90S-4	1420	7.60	71	0.89	3.8	0.32	1.7	25/400	0.002780	20.0	14.7
1.50	2.00	ER90L-4	1410	9.50	74	0.93	3.8	0.30	1.7	30/400	0.003430	21.8	16.5
2.20	3.00	ER100LB-4	1430	13.80	73	0.95	4.2	0.35	1.9	60/450	0.003543	30.0	21.0

1500 rpm

0.55	0.75	ERR80B-4	1400	4.5	60	0.91	3.0	0.65	1.7	25/400	0.001530	-	9.3
0.75	1.0	ERR80C-4	1410	5.4	66	0.92	3.4	0.60	1.7	30/400	0.001670	-	10.7
1.10	1.50	ERR90S-4	1400	7.5	69	0.94	3.8	0.65	2.0	40/400	0.002600	-	15.0
1.50	2.00	ERR90L-4	1390	9.4	72	0.96	3.8	0.60	2.	50/400	0.003470	-	17.6

TYPE OF EXECUTION B3

BAUFORM B3

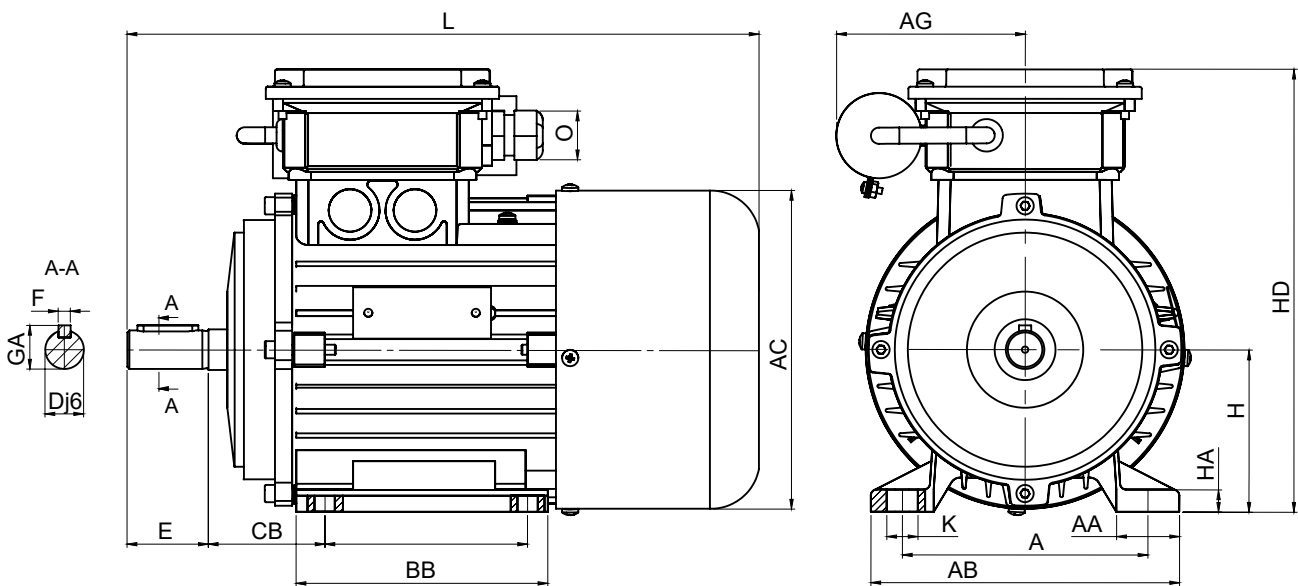

Type	Dimensions, mm																	
Typ	Abmessungen, mm																	
	A	AA	AB	AC	AG	B	BB	C	D	E	F	GA	H	HA	HD	L	K	O
ER63	100	20	120	123	80	80	105	40	11	23	4	125	63	10	165	216	7	M16
ER71	112	24	136	140	85	90	108	45	14	30	5	16	71	11	180	236		
ER, ERR80	125	29	150	157		105	100	125	50	19	40	6	21.5	80	10	193	274	10
ER, ERR90S	140	34	175	174	130			56	24	50	8	27	90	14	214	307		
ER, ERR90L					125		155	332										
ER100LB	160	32	200	192	140	175	63	28	60	31	100	230	375	12				

TYPE OF EXECUTION B5

BAUFORM B5

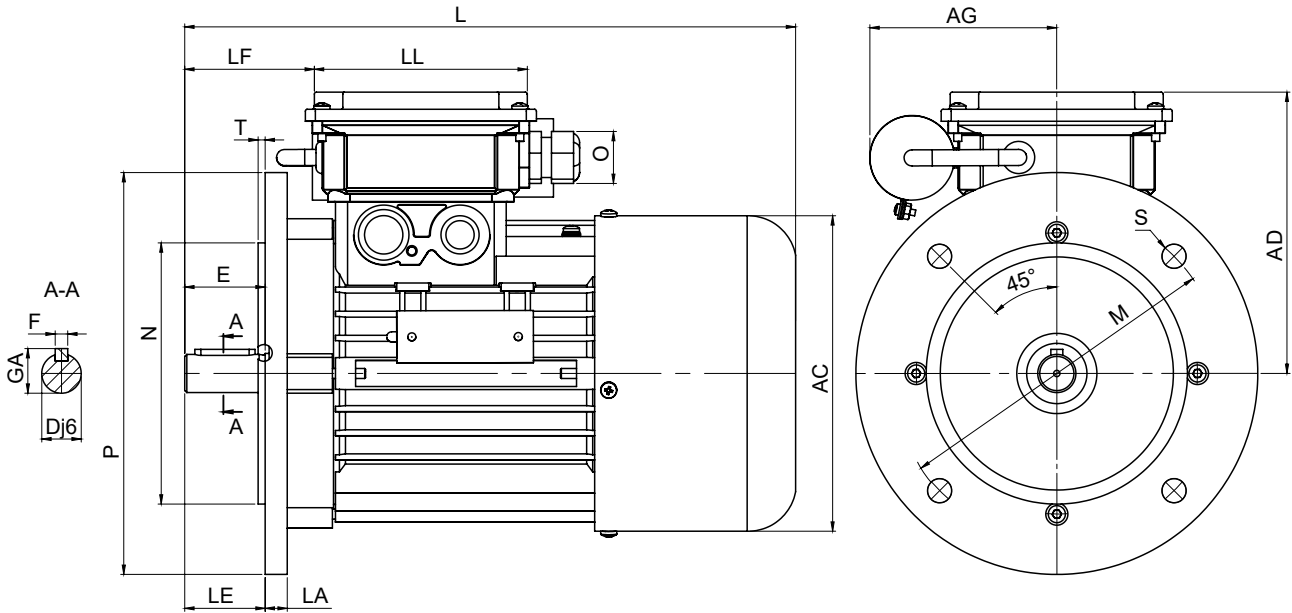

Type	Dimensions, mm																	
Typ	Abmessungen, mm																	
	Flande	AC	AD	AG	D	E	F	GA	L	LE	LF	LL	M	N	O	P	S	T
ER63	A140	123	117	80	11	23	4	12.5	216	23	50	65	115	95	M16	140	9	3
ER71	A140	140	127	85	14	30	5	16	236	30	65		130	110		160		
	A160				19	40	6	21.5	274	40	76	165	130	200	12			
ER, ERR80	A160	157	136	105	24	50	8	27	307	50	90	78	130	110	M20	160	9	3.5
	A200												165	130		200	12	
ER, ERR90S	A160	174	149	105	24	50	8	27	361	50	90	78	130	110	M20	160	9	3.5
	A200												165	130		200	12	
ER, ERR90L	A160	174	149	105	24	50	8	27	361	50	90	78	130	110	M20	160	9	3.5
	A200												165	130		200	12	
ER100	A200	192	150	105	28	60	8	31	406	60	106	78	165	130	M20	200	12	3.5
	A250												215	180		250	14	

TYPE OF EXECUTION B14

BAUFORM B14

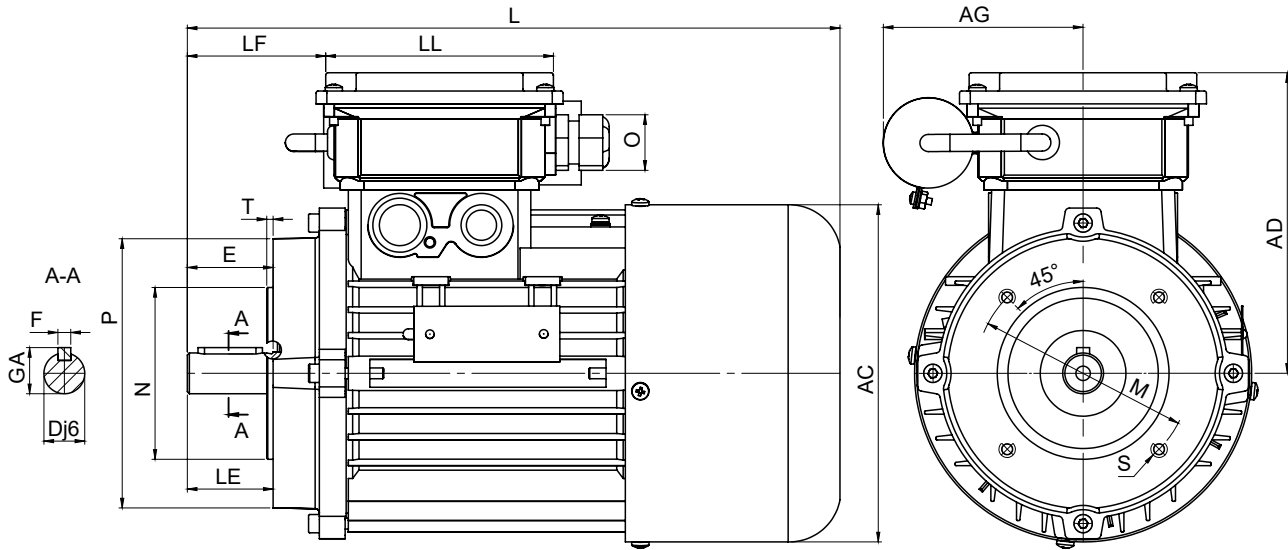

Type	Dimensions, mm																	
Typ	Abmessungen, mm																	
	Flande	AC	AD	AG	D	E	F	GA	L	LE	LF	LL	M	N	O	P	S	T
ER63	F75	123	102	80	11	23	4	12.5	216	23	50	65	75	60	M16	90	M5	2.5
	F100												100	80				
ER71	F85	140	112	85	14	30	5	16	236	30	65	65	85	70	M16	105	M6	2.5
	F115												115	95				
ER, ERR80	F100	157	127	85	19	40	6	21.5	274	40	76	65	100	80	M16	120	M6	3.5
	F130												130	110				
ER, ERR90S	F115	174	132	98	24	50	8	27	307	50	90	78	115	95	M20	140	M8	3
	F130												130	110				
ER, ERR90L	F115	174	132	98	24	50	8	27	332	50	90	78	115	95	M20	140	M8	3
	F130												130	110				
ER100	F130	192	142	98	28	60	8	31	375	60	106	78	130	110	M20	160	M10	3.5
	F165												130	110				

Rated Output		Type	Parameters at Rated Output				Starting characteristics			Capacitors - Capacitance at Voltage		Torque of Inertia	Weight	
			Rotation speed	Current	Efficiency	Power Factor	Current	Torque		Starting	Running		Cast Iron	All alloy
								$I_s/I_R$	$M_s/M_R$			$M_{MAX}/M_R$		
$P_2$	Indication	n	$I_R$	$\eta$	$\cos\phi$	$I_s/I_R$	$M_s/M_R$	$M_{MAX}/M_R$	AB1.7%ED	DB	J	m		
kW	HP	rpm	A	%					$\mu F/V$		kg.m <sup>2</sup>	kg		

3000 rpm

0.75	1.00	ESR80B-2	2890	4.4	78	0.95	5.3	1.9	2.1	70/280	20/400	0.00100	-	11.1
1.10	1.50	ESR80C-2	2860	6.9	72	0.97	4.6	1.7	1.9	90/280	30/400	0.00110	-	12.0
1.50	2.00	ESR90S-2	2880	9.3	76	0.91	5.3	1.9	2.1	140/280	35/400	0.00163	24.0	15.7
2.2	3.00	ESR90L-2	2870	13.8	76	0.91	5.0	1.7	2.0	140/280	45/400	0.00255	26.0	17.7
3.0	4.00	ESR100LB-2	2890	17.7	75	0.98	4.4	1.7	1.9	140/280	60/400	-	30.0	21.0

1500 rpm

0.55	0.75	ESR80B-4	1420	4.0	66	0.90	3.8	1.6	1.7	45/280	16/400	0.00153	-	9.8
0.75	1.00	ESR80C-4	1410	5.5	66	0.91	3.8	1.6	1.6	55/280	20/400	0.0067	-	10.7
1.10	1.50	ESR90S-4	1420	7.6	71	0.89	4.8	1.9	1.7	140/280	25/400	0.00290	24.2	15.5
1.50	2.00	ESR90L-4	1410	9.5	74	0.93	4.8	1.7	1.7	140/280	30/400	0.00258	26.2	17.4
2.20	3.00	ESR100LB-4	1440	14.3	73	0.92	4.5	1.4	1.8	140/280	45/450	0.00655	30.0	22.0

TYPE OF EXECUTION B3

BAUFORM B3

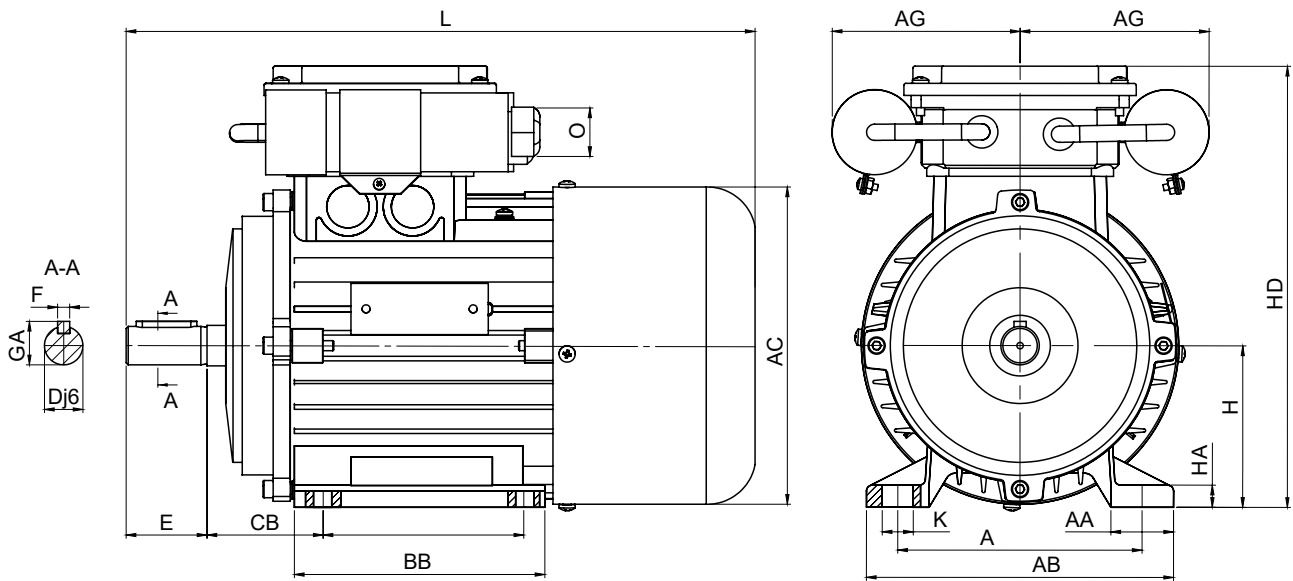

Type	Dimensions, mm																	
Typ	Abmessungen, mm																	
	A	AA	AB	AC	AG	B	BB	C	D	E	F	GA	H	HA	HD	L	K	O
ESR80	125	29	150	157	85	100	125	50	19	40	6	21.5	80	10	193	277	10	M20
ESR90S	140	34	175	74	105		130	56	24	50	8	27	90		214	345		
ESR90L						125	155							370				
ESR100	160	32	200	192	140	175	63	28	60	31	100	14	230		400	12		

TYPE OF EXECUTION B5

BAUFORM B5

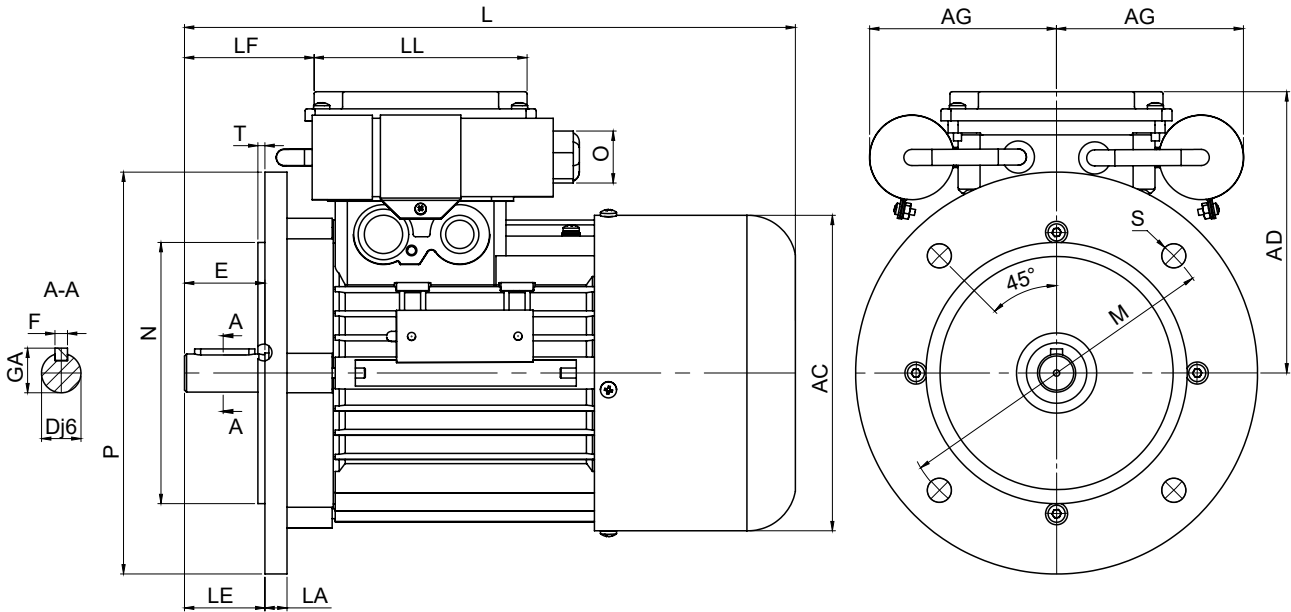

Type	Dimensions, mm																	
Typ	Abmessungen, mm																	
	Flande	AC	AD	AG	D	E	F	GA	L	LE	LF	LL	M	N	O	P	S	T
ESR80		157	127	80	19	40	6	21.5	277	40	76		165	130		200		
ESR90S	A200	174	32	98	24	50	8	27	345	50	90	78	165	130	M20	200	12	3.5
ESR90L									370									
ESR100	A250	192	142		28	60		31	400	60	106		215	180		250	14	

TYPE OF EXECUTION B14

BAUFORM B14

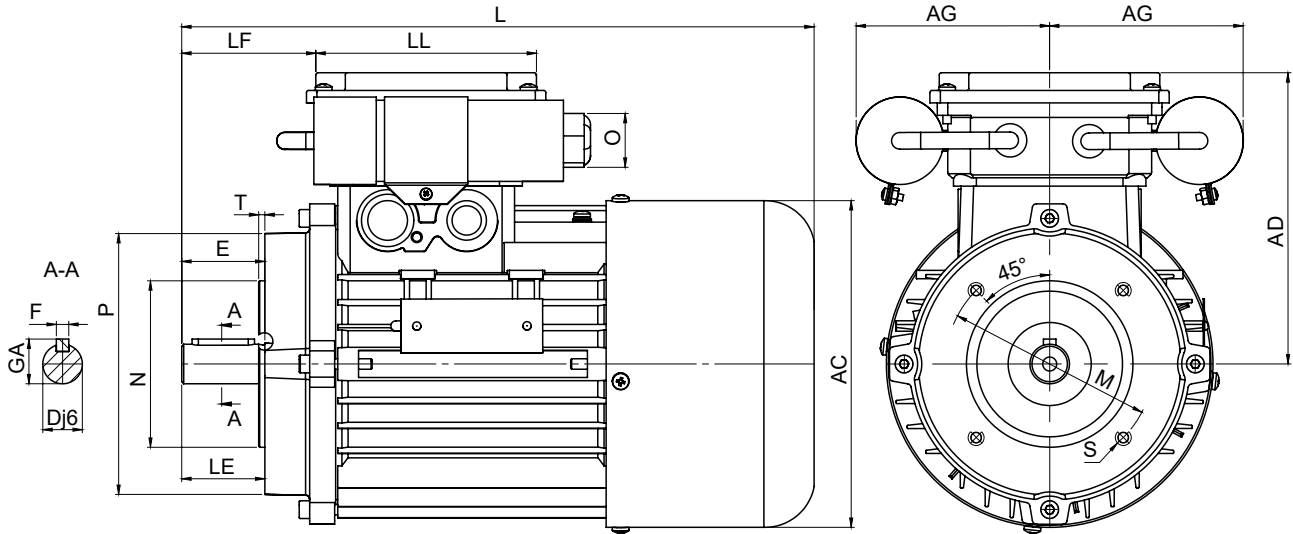

Type	Dimensions, mm																	
Typ	Abmessungen, mm																	
	Flande	AC	AD	AG	D	E	F	GA	L	LE	LF	LL	M	N	O	P	S	T
ESR80	F100	157	127	85	19	40	6	21.5	277	40	76		100	80		120	M6	
	F130												130	110		160		
ESR90S	F115	174	132	98	24	50	8	27	345	50	90	78	115	95	M20	140	M8	3.5
	F130												130	110		160		
ESR90L	F115	174	132	98	24	50	8	27	370	50	90	78	115	95	M20	140	M8	3.5
	F130												130	110		160		
ESR100	F130	192	142	98	28	60	8	31	400	60	106		130	110		160	M10	
	F165												165	130		200		

**SERIES T, TH, TP**  
 THREE PHASE ASYNCHRONOUS  
 ELECTRIC MOTORS

**SERIE T, TH, TP**  
 DREHESTROM-ASYNCHRON  
 MOTOREN

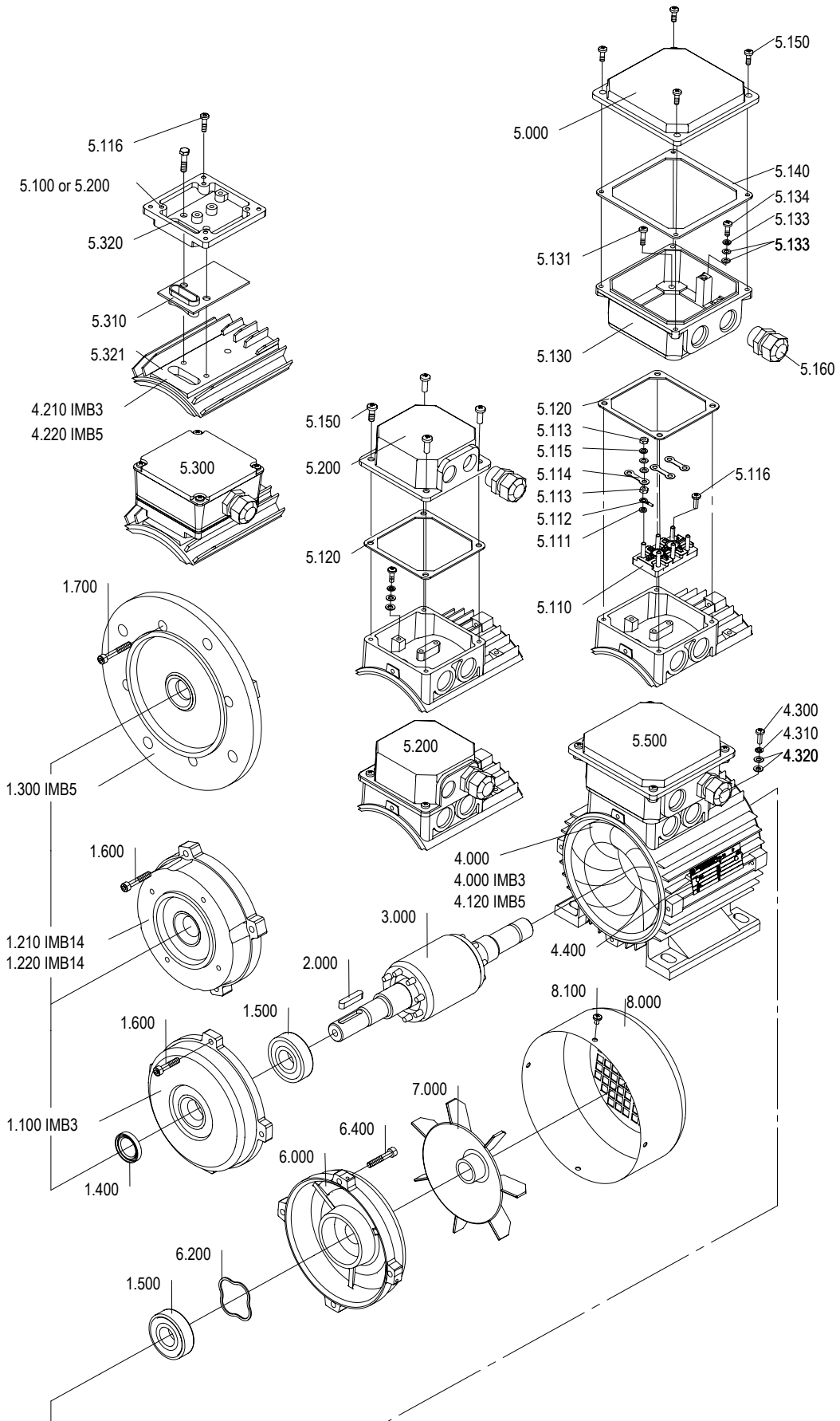

## SERIES T, TH, TP

THREE PHASE ASYNCHRONOUS  
ELECTRIC MOTORS

## SERIE T, TH, TP

DREHESTROM-ASYNCHRON  
MOTOREN

- 1.100 Front bearing shield IMB3
- 1.210 Flange bearing shield IMB14 small
- 1.220 Flange bearing shield IMB14 large
- 1.300 Flange bearing shield IMB5
- 1.400 Radial oil seal IP55

3.000 Rotor

- 4.000 Stator
- 4.110 Stator with aluminium frame IMB3
- 4.120 Stator with aluminium frame IMB5
- 4.210 Stator with cast-iron frame IMB3
- 4.220 Stator with cast-iron frame IMB5
- 4.400 Nameplate
- 4.500 Gasket

- 5.500 Aluminium terminal box-complete
- 5.110 Terminal board
- 5.112 Terminal
- 5.114 Connection plate
- 5.120 Gasket
- 5.130 Aluminium terminal box
- 5.140 Gasket
- 5.150 Aluminium box cover

- 5.200 Plastic terminal box
- 5.210 Gasket
- 5.220 Plastic terminal box

- 5.300 Terminal box for electric motors with cast - iron frame
- 5.310 Gasket
- 5.320 Base of the terminal box

- 6.000 Back bearing shield
- 6.200 Spacing ring
- 6.300 Ring

7.000 Fan - complete

8.000 Fan cover

5.113 DIN 555



4.310  
5.115 DIN 127  
5.133



4.320  
5.111 DIN 46320  
5.132



1.600  
4.300  
5.321  
6.400  
DIN 933

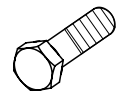

1.700  
1.600  
DIN 6912

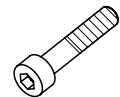

5.116  
5.131  
5.134  
5.151  
8.100  
DIN 7985



2.000  
DIN 6885



1.500  
DIN 625



5.160  
EN 50262



6.100  
6.110  
DIN 471



# SERIES T-BR

THREE PHASE ASYNCHRONOUS ELECTRIC  
MOTORS WITH BRAKE

# SERIE T-BR

DREHESTROM-ASYNCHRONMOTOREN  
MIT BREMSE

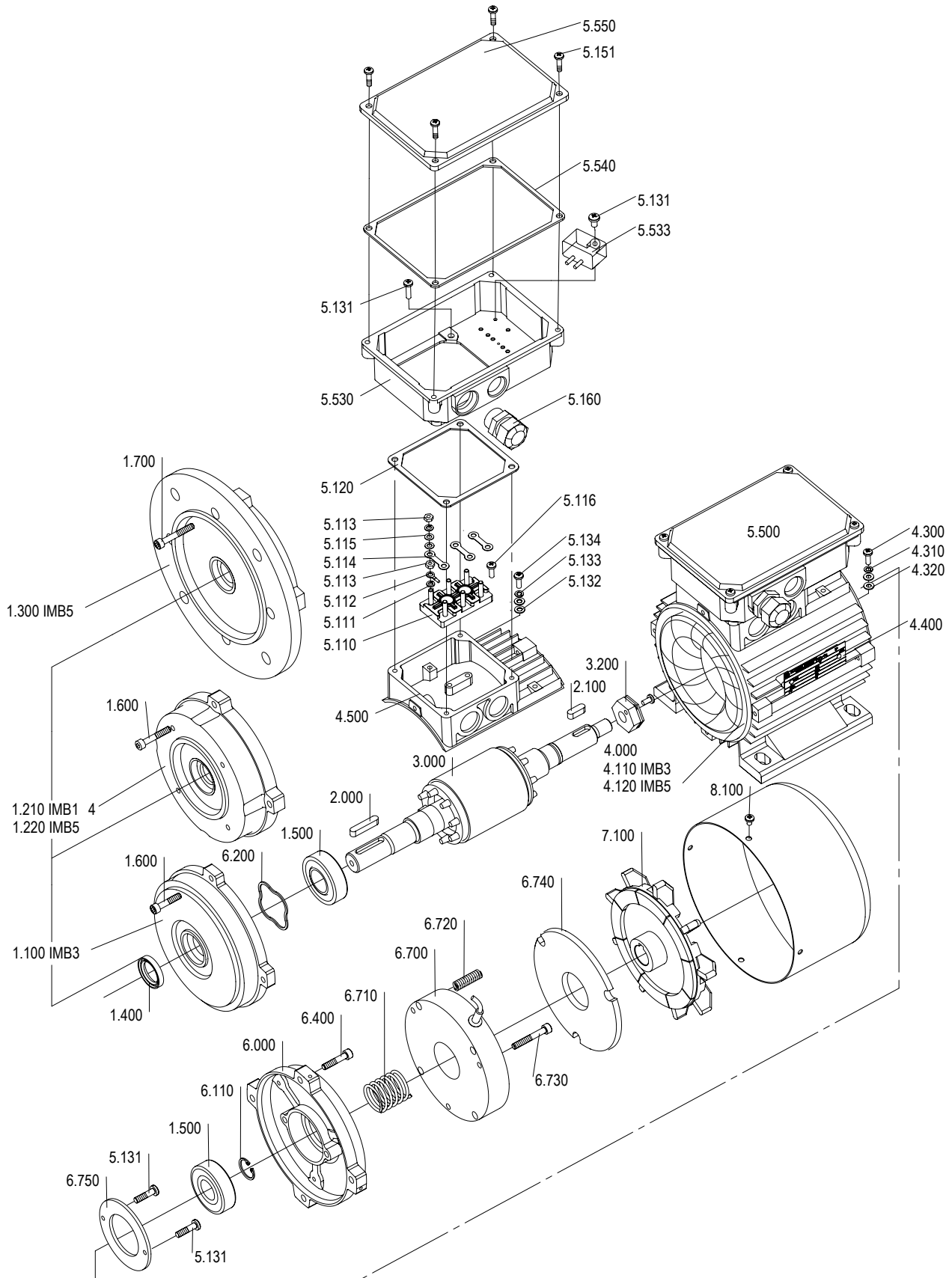

## SERIES T-BR

THREE PHASE ASYNCHRONOUS ELECTRIC  
MOTORS WITH BRAKE

## SERIE T-BR

DREHESTROM-ASYNCHRONMOTOREN  
MIT BREMSE

1.100 Front bearing shield IMB3  
1.210 Flange bearing shield IMB14 small  
1.220 Flange bearing shield IMB14 large  
1.300 Flange bearing shield IMB5  
1.400 Radial oil seal IP55

3.000 Rotor  
3.200 Special nut

4.000 Stator  
4.110 Stator with aluminium frame IMB3  
4.120 Stator with aluminium frame IMB5  
4.400 Nameplate  
4.500 Gasket

5.500 Aluminium terminal box-complete  
5.110 Terminal board  
5.112 Terminal  
5.114 Connection plate  
5.120 Gasket  
5.530 Aluminium terminal box  
5.533 Rectifier  
5.550 Cover

6.000 Back bearing shield  
6.200 Spacing ring  
6.700 Electromagnet  
6.710 Spring, big  
6.720 Spring, small  
6.740 Anchor  
6.750 Bearing cap

7.000 Fan - complete

8.000 Fan cover

5.113 DIN555



4.310  
5.115 DIN 127  
5.133



4.320  
5.111 DIN 46320  
5.132



1.700  
6.730 DIN 6912

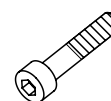

5.116  
5.131  
5.134 DIN 7985  
5.151  
8.100



2.000  
2.100 DIN 6885



1.500 DIN 625



5.160 EN 50262



6.100  
6.110 DIN 471



# SERIES T-42

THREE-PHASE ELECTRIC MOTORS FOR DRIVING  
MONORAIL HOISTS AND TROLLEYS

# SERIES T-42

DREIPHASIGE ASYNCHRONE ELEKTROMOTOREN FÜR DAS  
FAHREN VON MONORAIL-HUBS UND TROLLEYS

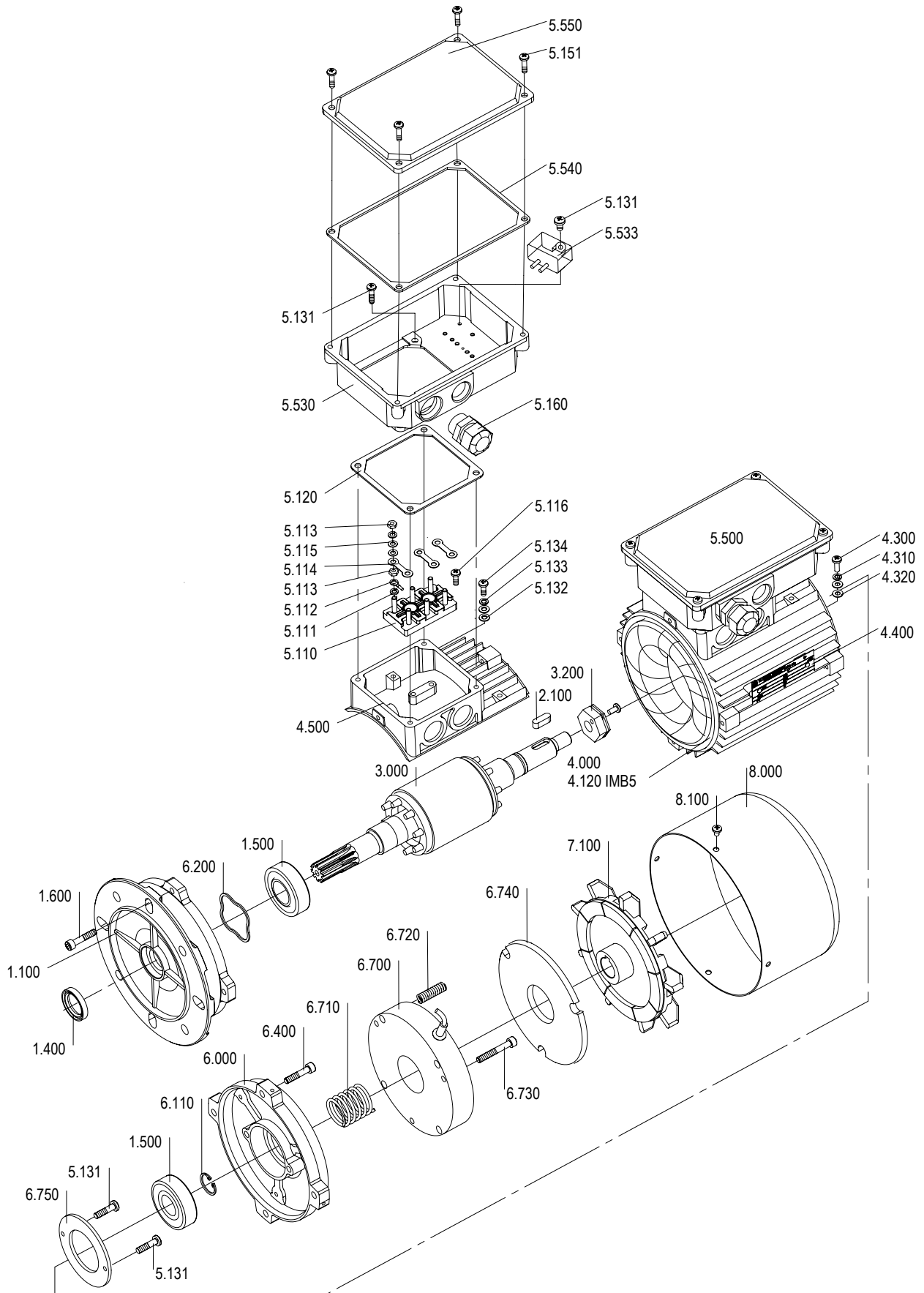

## SERIES T-42

THREE-PHASE ELECTRIC MOTORS FOR DRIVING  
MONORAIL HOISTS AND TROLLEYS

## SERIES T-42

DREIPHASIGE ASYNCHRONE ELEKTROMOTOREN FÜR DAS  
FAHREN VON MONORAIL-HUBS UND TROLLEYS

1.100 Front bearing shield  
1.100 Vorderes Lagerschild  
1.400 Radial oil seal IP55  
1.400 Radialöldichtring für IP55

3.000 Rotor  
3.000 Rotor  
3.200 Special nut  
3.200 Spezialmutter

4.000 Stator  
4.000 Stator  
4.120 Stator with aluminium frame IMB5  
4.120 Stator mit Aluminiumkörper IMB5  
4.400 Nameplate  
4.400 Namensschild  
4.500 Gasket  
4.500 Dichtung

5.500 Aluminium terminal box-set  
5.500 Aluminiumklemmenkasten - Set  
5.110 Terminal board  
5.110 Anschlussfeld  
5.112 Terminal  
5.112 Stiftleiter  
5.114 Connection plate  
5.114 Bindplatte  
5.120 Gasket  
5.120 Dichtung  
5.530 Aluminium terminal box  
5.530 Aluminiumanschlusskasten  
5.533 Rectifier  
5.533 Gleichrichter  
5.550 Cover  
5.550 Deckel

6.000 Rear bearing shield  
6.000 Hinteres Lagerschild  
6.200 Spacing ring  
6.200 Sicherungsblech  
6.700 Electromagnet  
6.700 Elektromagnet  
6.710 Spring, big  
6.710 Frühling groß  
6.720 Spring, small  
6.720 Frühling klein  
6.740 Anchor  
6.740 Anker  
6.750 Bearing cap  
6.750 Lagerverschluß

7.000 Fan - set  
7.000 Lüfter - Satz

8.000 Fan cover  
8.000 Mantel

5.113 DIN555



4.310  
5.115 DIN 127  
5.133



4.320  
5.111 DIN 46320  
5.132



1.600  
6.730 DIN 6912

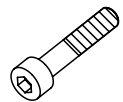

5.116  
5.131  
5.134 DIN 7985  
5.151  
8.100



2.100 DIN 6885



1.500 DIN 625



5.160 EN 50262

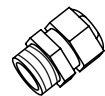

6.100  
6.110 DIN 471



# SERIES KT

THREE-PHASE ELECTRIC MOTORS FOR DRIVING  
MONORAIL HOISTS AND TROLLEYS

# SERIES KT

DREIPHASIGE ASYNCHRONE ELEKTROMOTOREN FÜR DAS  
FAHREN VON MONORAIL-HUBS UND TROLLEYS

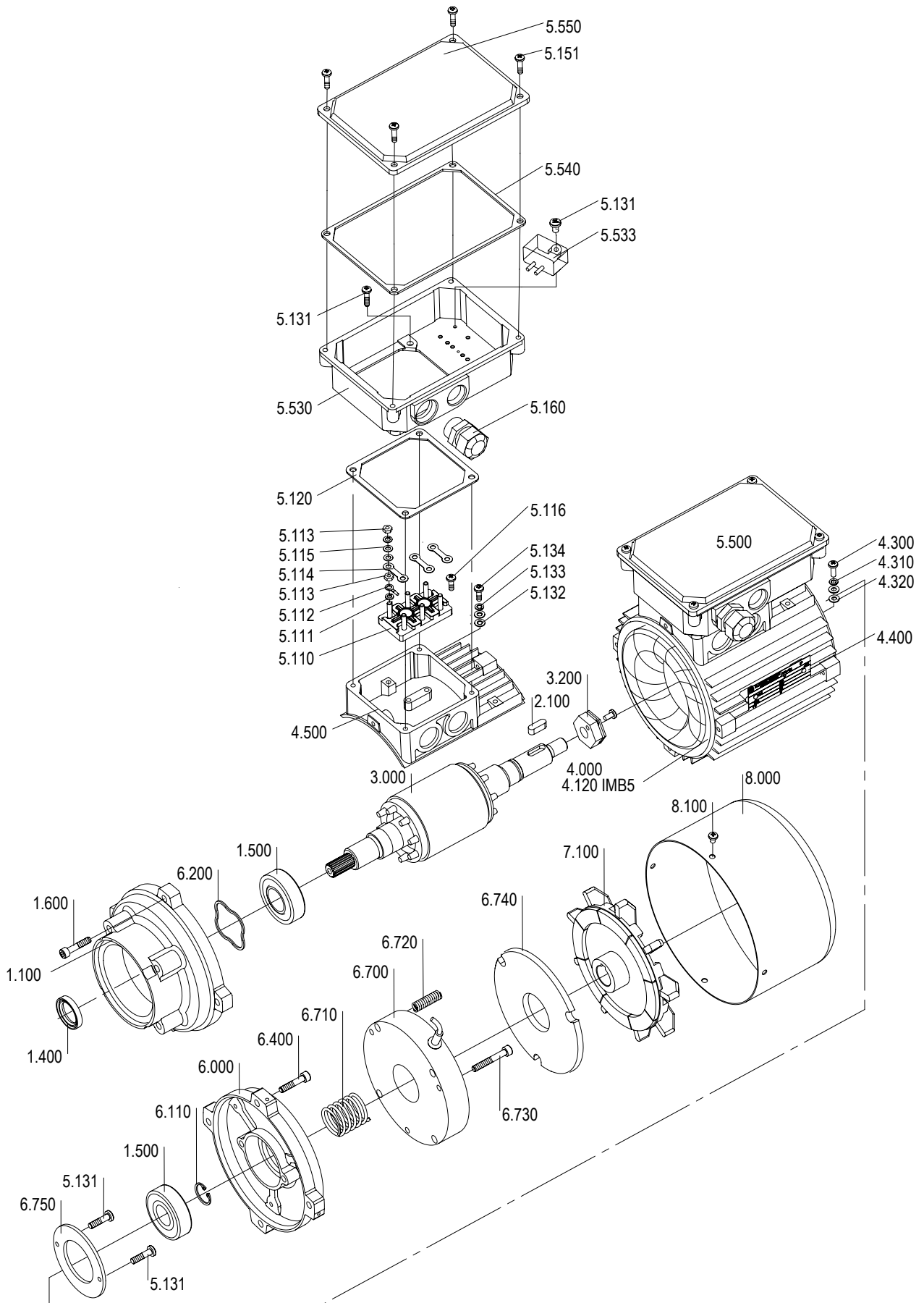

## SERIES KT

THREE-PHASE ELECTRIC MOTORS FOR DRIVING  
MONORAIL HOISTS AND TROLLEYS

## SERIES KT

DREIPHASIGE ASYCNHRONE ELEKTROMOTOREN FÜR DAS  
FAHREN VON MONORAIL-HUBS UND TROLLEYS

1.100 Front bearing shield  
1.100 Vorderes Lagerschild  
1.400 Radial oil seal IP55  
1.400 Radialöldichtring für IP55

3.000 Rotor  
3.000 Rotor  
3.200 Special nut  
3.200 Spezialmutter

4.000 Stator  
4.000 Stator  
4.120 Stator with aluminium frame IMB5  
4.120 Stator mit Aluminiumkörper IMB5  
4.400 Nameplate  
4.400 Namensschild  
4.500 Gasket  
4.500 Dichtung

5.500 Aluminium terminal box-set  
5.500 Aluminiumklemmenkasten - Set

5.110 Terminal board  
5.110 Anschlussfeld  
5.112 Terminal  
5.112 Stiftleiter  
5.114 Connection plate  
5.114 Bindplatte

5.120 Gasket  
5.120 Dichtung  
5.530 Aluminium terminal box  
5.530 Aluminiumanschlusskasten  
5.533 Rectifier  
5.533 Gleichrichter  
5.550 Cover  
5.550 Deckel

6.000 Rear bearing shield  
6.000 Hinteres Lagerschild  
6.200 Spacing ring  
6.200 Sicherungsblech  
6.700 Electromagnet  
6.700 Elektromagnet  
6.710 Spring, big  
6.710 Frühling groß  
6.720 Spring, small  
6.720 Frühling klein  
6.740 Anchor  
6.740 Anker  
6.750 Bearing cap  
6.750 Lagerverschluß

7.000 Fan - set  
7.000 Lüfter - Satz

8.000 Fan cover  
8.000 Mantel

5.113 DIN555



4.310  
5.115 DIN 127  
5.133



4.320  
5.111 DIN 46320  
5.132



1.600  
6.730 DIN 6912



5.116  
5.131  
5.134 DIN 7985  
5.151  
8.100



2.100 DIN 6885



1.500 DIN 625



5.160 EN 50262

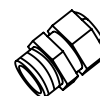

6.100  
6.110 DIN 471



# SERIES KT-35

THREE-PHASE ELECTRIC MOTORS FOR DRIVING  
MONORAIL HOISTS AND TROLLEYS

# SERIES KT-35

DREIPHASIGE ASYNCHRONE ELEKTROMOTOREN FÜR DAS  
FAHREN VON MONORAIL-HUBS UND TROLLEYS

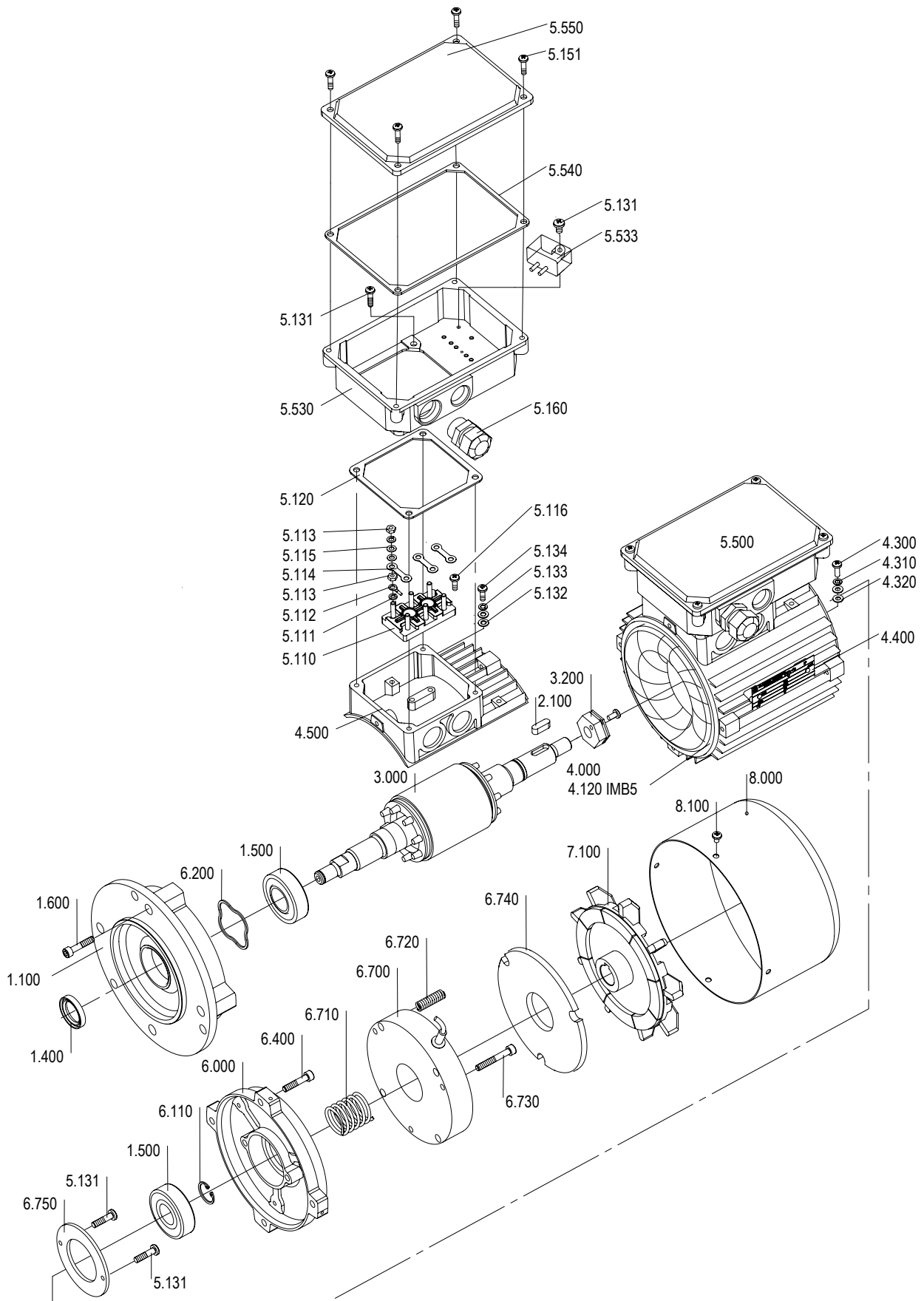

## SERIES KT-35

THREE-PHASE ELECTRIC MOTORS FOR DRIVING  
MONORAIL HOISTS AND TROLLEYS

## SERIES KT-35

DREIPHASIGE ASYNCHRONE ELEKTROMOTOREN FÜR DAS  
FAHREN VON MONORAIL-HUBS UND TROLLEYS

1.100 Front bearing shield  
1.100 Vorderes Lagerschild  
1.400 Radial oil seal IP55  
1.400 Radialöldichtring für IP55

3.000 Rotor  
3.000 Rotor  
3.200 Special nut  
3.200 Spezialmutter

4.000 Stator  
4.000 Stator  
4.120 Stator with aluminium frame IMB5  
4.120 Stator mit Aluminiumkörper IMB5  
4.400 Nameplate  
4.400 Namensschild  
4.500 Gasket  
4.500 Dichtung

5.500 Aluminium terminal box-set  
5.500 Aluminiumklemmenkasten - Set  
5.110 Terminal board  
5.110 Anschlussfeld  
5.112 Terminal  
5.112 Stiftleiter  
5.114 Connection plate  
5.114 Bindplatte  
5.120 Gasket  
5.120 Dichtung  
5.530 Aluminium terminal box  
5.530 Aluminiumanschlusskasten  
5.533 Rectifier  
5.533 Gleichrichter  
5.550 Cover  
5.550 Deckel

6.000 Rear bearing shield  
6.000 Hinteres Lagerschild  
6.200 Spacing ring  
6.200 Sicherungsblech  
6.700 Electromagnet  
6.700 Elektromagnet  
6.710 Spring, big  
6.710 Frühling groß  
6.720 Spring, small  
6.720 Frühling klein  
6.740 Anchor  
6.740 Anker  
6.750 Bearing cap  
6.750 Lagerverschluß

7.000 Fan - set  
7.000 Lüfter - Satz

8.000 Fan cover  
8.000 Mantel

5.113 DIN555



4.310  
5.115 DIN 127  
5.133



4.320  
5.111 DIN 46320  
5.132



1.600  
6.730 DIN 6912

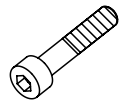

5.116  
5.131  
5.134 DIN 7985  
5.151  
8.100



2.100 DIN 6885



1.500 DIN 625



5.160 EN 50262



6.100  
6.110 DIN 471



# SERIES KT-53

THREE-PHASE ELECTRIC MOTORS FOR DRIVING  
MONORAIL HOISTS AND TROLLEYS

# SERIES KT-53

DREIPHASIGE ASYNCHRONE ELEKTROMOTOREN FÜR DAS  
FAHREN VON MONORAIL-HUBS UND TROLLEYS

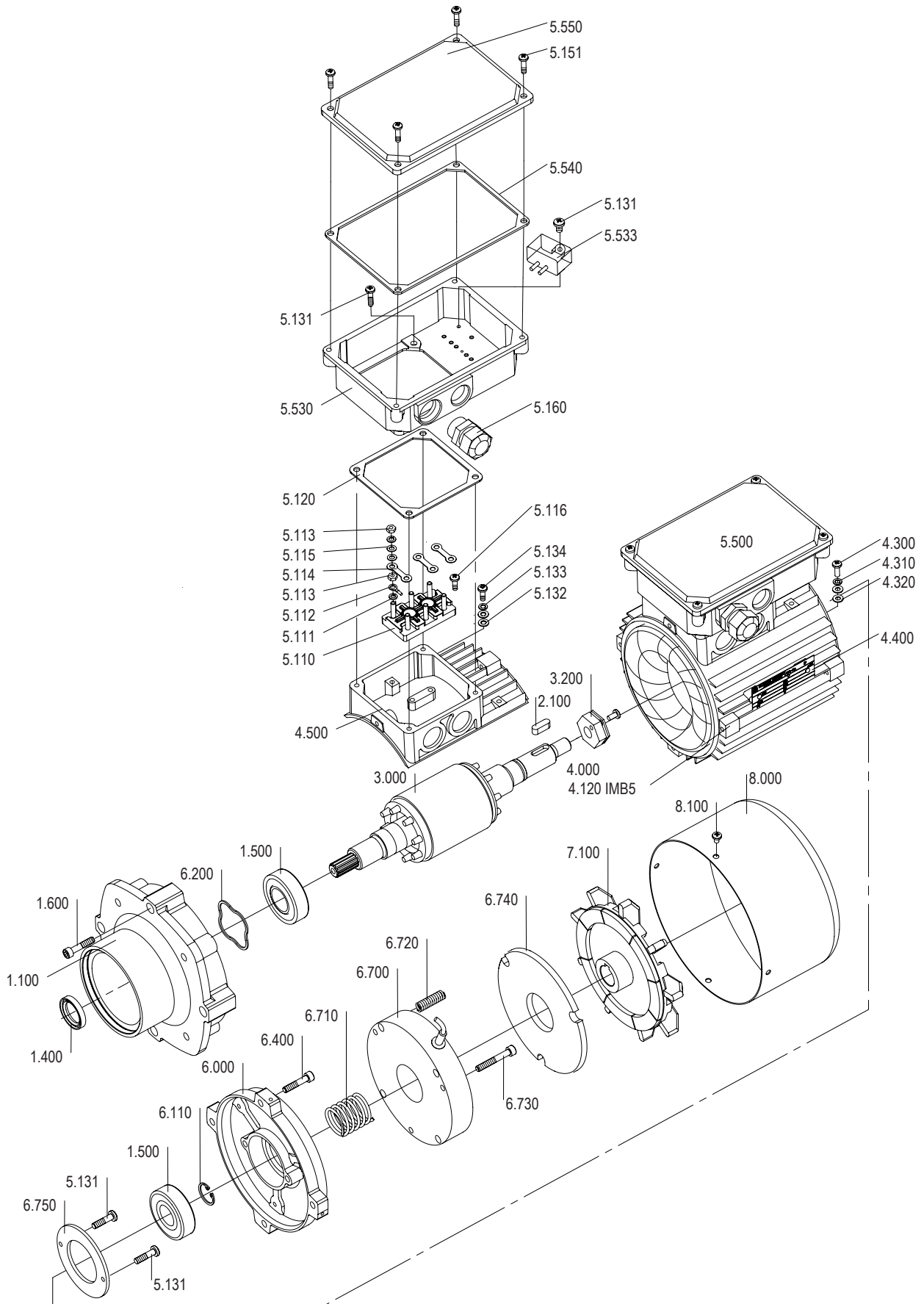

## SERIES KT-53

THREE-PHASE ELECTRIC MOTORS FOR DRIVING  
MONORAIL HOISTS AND TROLLEYS

## SERIES KT-53

DREIPHASIGE ASYNCHROME ELEKTROMOTOREN FÜR DAS  
FAHREN VON MONORAIL-HUBS UND TROLLEYS

- 1.100 Front bearing shield
- 1.100 Vorderes Lagerschild
- 1.400 Radial oil seal IP55
- 1.400 Radialöldichtring für IP55
  
- 3.000 Rotor
- 3.000 Rotor
- 3.200 Special nut
- 3.200 Spezialmutter
  
- 4.000 Stator
- 4.000 Stator
- 4.120 Stator with aluminium frame IMB5
- 4.120 Stator mit Aluminiumkörper IMB5
- 4.400 Nameplate
- 4.400 Namensschild
- 4.500 Gasket
- 4.500 Dichtung
  
- 5.500 Aluminium terminal box-set
- 5.500 Aluminiumklemmenkasten - Set
- 5.110 Terminal board
- 5.110 Anschlussfeld
- 5.112 Terminal
- 5.112 Stiftleiter
- 5.114 Connection plate
- 5.114 Bindplatte
- 5.120 Gasket
- 5.120 Dichtung
- 5.530 Aluminium terminal box
- 5.530 Aluminiumanschlusskasten
- 5.533 Rectifier
- 5.533 Gleichrichter
- 5.550 Cover
- 5.550 Deckel
  
- 6.000 Rear bearing shield
- 6.000 Hinteres Lagerschild
- 6.200 Spacing ring
- 6.200 Sicherungsblech
- 6.700 Electromagnet
- 6.700 Elektromagnet
- 6.710 Spring, big
- 6.710 Frühling groß
- 6.720 Spring, small
- 6.720 Frühling klein
- 6.740 Anchor
- 6.740 Anker
- 6.750 Bearing cap
- 6.750 Lagerverschluß
  
- 7.000 Fan - set
- 7.000 Lüfter - Satz
  
- 8.000 Fan cover
- 8.000 Mantel

5.113 DIN555



4.310  
5.115 DIN 127  
5.133



4.320  
5.111 DIN 46320  
5.132



1.600  
6.730 DIN 6912

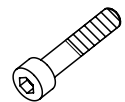

5.116  
5.131  
5.134 DIN 7985  
5.151  
8.100



2.100 DIN 6885



1.500 DIN 625



5.160 EN 50262

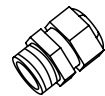

6.100  
6.110 DIN 471



# SERIES CT-K

THREE-PHASE ASYNCHRONOUS ELECTRIC  
MOTORS FOR HOISTING DRIVE MECHANIS

# SERIE CT-K

ASYNCHRONELEKTROMOTOREN FÜR  
HEBEZUGMECHANISMEN VON ELEKTROZUGEN

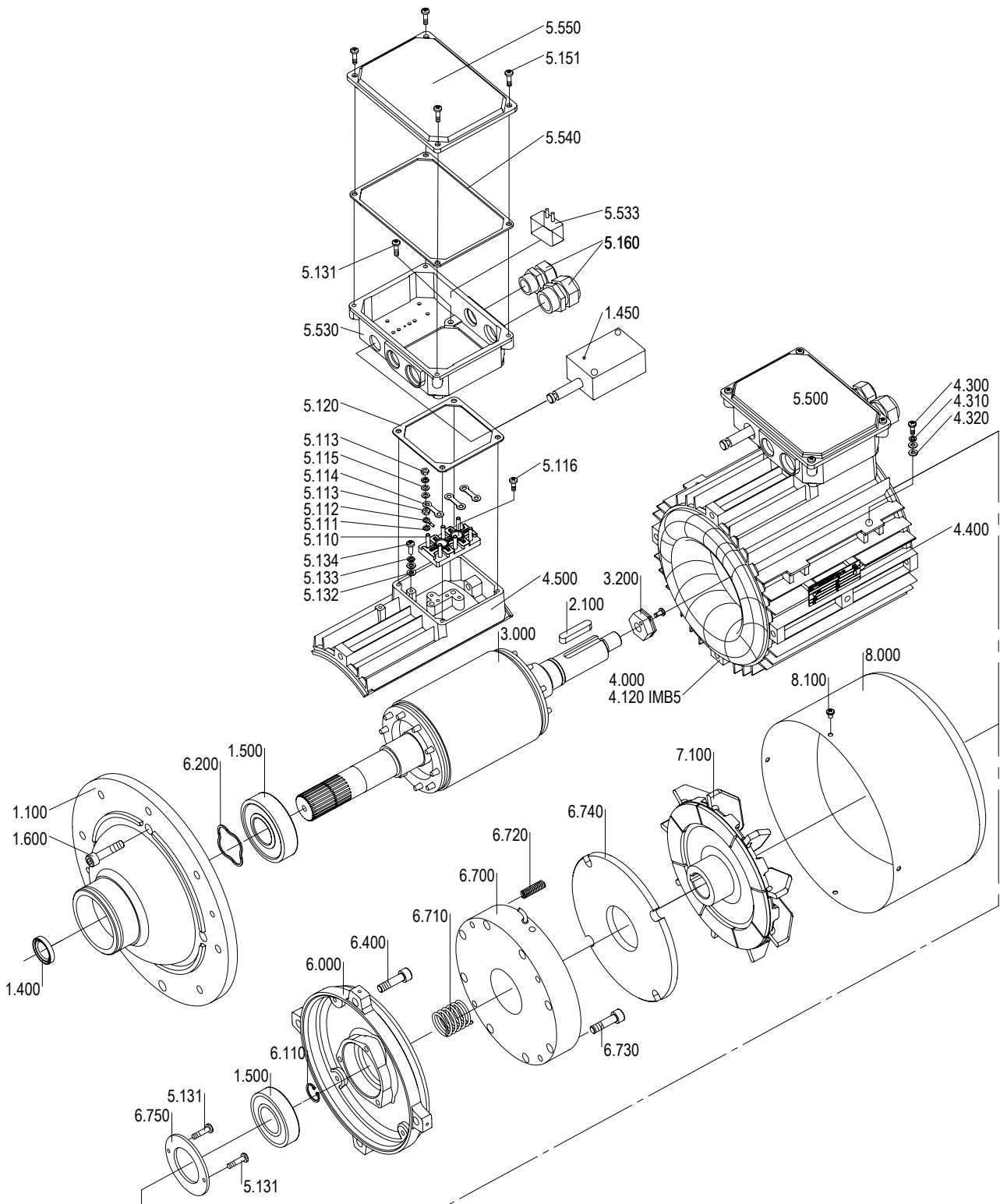

## SERIES CT-K

THREE-PHASE ASYNCHRONOUS ELECTRIC  
MOTORS FOR HOISTING DRIVE MECHANIS

## SERIE CT-K

ASYNCHRONELEKTROMOTOREN FÜR  
HEBEZUGMECHANISMEN VON ELEKTROZUGEN

- 1.100 Front bearing shield
- 1.100 Vorderes Lagerschild
- 1.400 Radial oil seal IP55
- 1.400 Radialöldichtring für IP55
- 1.450 Final switch
- 1.450 Endschalter
  
- 3.000 Rotor
- 3.000 Rotor
- 3.200 Special nut
- 3.200 Spezialmutter
  
- 4.000 Stator
- 4.000 Stator
- 4.120 Stator with aluminium frame IMB5
- 4.120 Stator mit Aluminiumkörper
- 4.400 Nameplate
- 4.400 Namensschild
- 4.500 Gasket
- 4.500 Dichtung
  
- 5.500 Aluminium terminal box-set
- 5.500 Aluminiumklemmenkasten - Set
- 5.110 Terminal board
- 5.110 Anschlussfeld
- 5.112 Terminal
- 5.112 Stiftleiter
- 5.114 Connection plate
- 5.114 Bindplatte
- 5.120 Gasket
- 5.120 Dichtung
- 5.530 Aluminium terminal box
- 5.530 Aluminiumanschlusskasten
- 5.533 Rectifier
- 5.533 Gleichrichter
- 5.550 Cover
- 5.550 Deckel
  
- 6.000 Rear bearing shield
- 6.000 Hinteres Lagerschild
- 6.200 Spacing ring
- 6.200 Sicherungsblech
- 6.700 Electromagnet
- 6.700 Elektromagnet
- 6.710 Spring, big
- 6.710 Frühling groß
- 6.720 Spring, small
- 6.720 Frühling klein
- 6.740 Anchor
- 6.740 Anker
- 6.750 Bearing cap
- 6.750 Lagerverschluß
  
- 7.000 Fan - set
- 7.000 Lüfter - Satz
  
- 8.000 Fan cover
- 8.000 Mantel

5.113 DIN555



4.310  
5.115 DIN 127  
5.133



4.320  
5.111 DIN 46320  
5.132



1.600  
6.730 DIN 6912

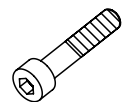

5.116  
5.131  
5.134 DIN 7985  
5.151  
8.100



2.100 DIN 6885



1.500 DIN 625



5.160 EN 50262



6.100  
6.110 DIN 471



**SERIES CT-240; 290; 360**  
 THREE-PHASE ASYNCHRONOUS ELECTRIC  
 MOTORS FOR HOISTING DRIVE MECHANIS

**SERIE CT-240; 290; 360**  
 ASYNCHRONELEKTROMOTOREN FÜR  
 HEBEZUGMECHANISMEN VON ELEKTROZUGEN

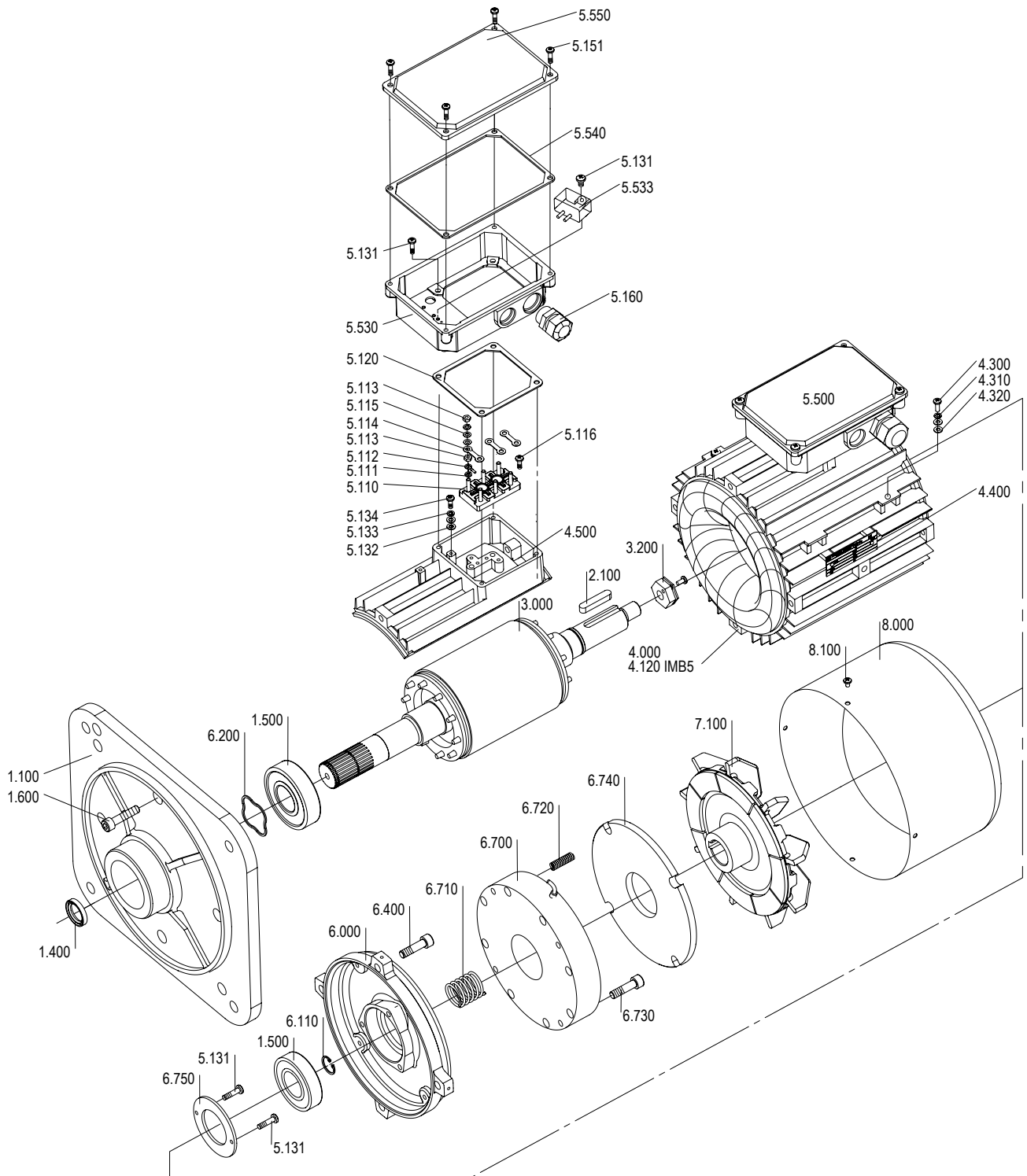

**SERIES CT-240; 290; 360**THREE-PHASE ASYNCHRONOUS ELECTRIC  
MOTORS FOR HOISTING DRIVE MECHANIS**SERIE CT-240; 290; 360**ASYNCHRONELEKTROMOTOREN FÜR  
HEBEZUGMECHANISMEN VON ELEKTROZUGEN

1.100 Front bearing shield  
1.100 Vorderes Lagerschild  
1.400 Radial oil seal IP55  
1.400 Radialöldichtring für IP55

3.000 Rotor  
3.000 Rotor  
3.200 Special nut  
3.200 Spezialmutter

4.000 Stator  
4.000 Stator  
4.120 Stator with aluminium frame IMB5  
4.120 Stator mit Aluminiumkörper IMB5  
4.400 Nameplate  
4.400 Namensschild  
4.500 Gasket  
4.500 Dichtung

5.500 Aluminium terminal box-set  
5.500 Aluminiumklemmenkasten - Set  
5.110 Terminal board  
5.110 Anschlussfeld  
5.112 Terminal  
5.112 Stiftleiter  
5.114 Connection plate  
5.114 Bindplatte  
5.120 Gasket  
5.120 Dichtung  
5.530 Aluminium terminal box  
5.530 Aluminiumanschlusskasten  
5.533 Rectifier  
5.533 Gleichrichter  
5.550 Cover  
5.550 Deckel

6.000 Rear bearing shield  
6.000 Hinteres Lagerschild  
6.200 Spacing ring  
6.200 Sicherungsblech  
6.700 Electromagnet  
6.700 Elektromagnet  
6.710 Spring, big  
6.710 Frühling groß  
6.720 Spring, small  
6.720 Frühling klein  
6.740 Anchor  
6.740 Anker  
6.750 Bearing cap  
6.750 Lagerverschluß

7.000 Fan - set  
7.000 Lüfter - Satz

8.000 Fan cover  
8.000 Mantel

5.113 DIN555

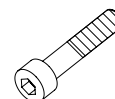
4.310  
5.115 DIN 127  
5.1334.320  
5.111 DIN 46320  
5.1321.600  
6.730 DIN 69125.116  
5.131  
5.134 DIN 7985  
5.151  
8.100

2.100 DIN 6885



1.500 DIN 625



5.160 EN 50262

6.100  
6.110 DIN 471

**SERIES ER, ERR**  
 SINGLE-PHASE ASYNCHRONOUS ELECTRIC  
 MOTORS WITH RUNNING CAPACITORS

**SERIE ER, ERR**  
 EINPHASEN-ASYNCHRONMOTOREN  
 MIT BETRIEBSKONDENSATOR

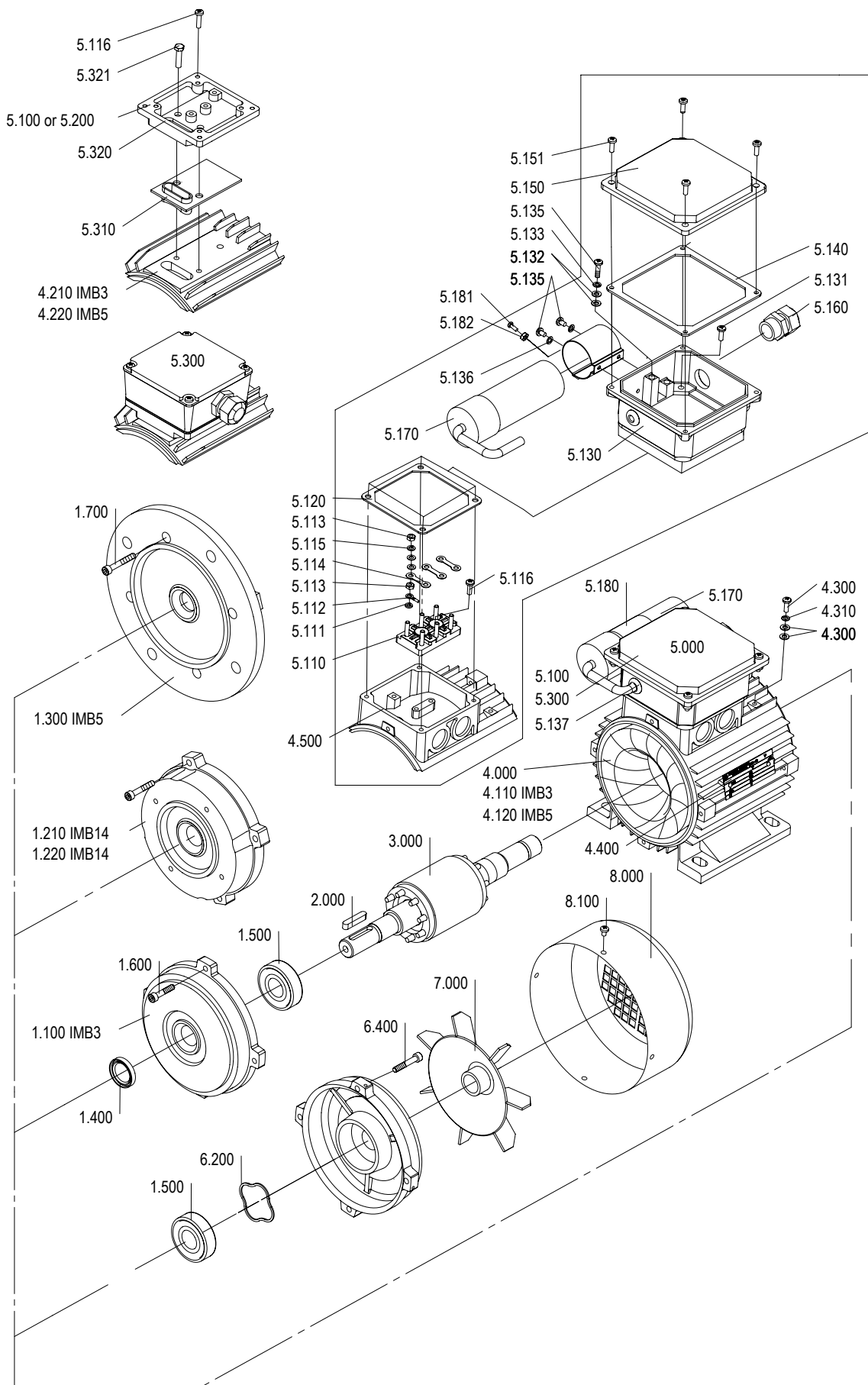

## SERIES ER, ERR

SINGLE-PHASE ASYNCHRONOUS ELECTRIC  
MOTORS WITH RUNNING CAPACITORS

## SERIE ER, ERR

EINPHASEN-ASYNCHRONMOTOREN  
MIT BETRIEBSKONDENSATOR

- 1.100 Front bearing shield IMB3
- 1.210 Flange bearing shield IMB14 small
- 1.220 Flange bearing shield IMB14 large
- 1.300 Flange bearing shield IMB5
- 1.400 Radial oil seal IP55

3.000 Rotor

4.000 Stator







- 4.110 Stator with aluminium frame IMB3
- 4.120 Stator with aluminium frame IMB5
- 4.210 Stator with cast - iron frame IMB3
- 4.220 Stator with cast - iron frame IMB5
- 4.400 Nameplate
- 4.500 Gasket

- 5.500 Aluminium terminal box-complete
- 5.100 Aluminium terminal box-complete  
and box cover
- 5.110 Terminal board
- 5.112 Terminal
- 5.114 Connection plate
- 5.120 Gasket
- 5.130 Aluminium terminal box-complete
- 5.137 Gasket
- 5.140 Gasket
- 5.150 Terminal box cover
- 5.170 Running capacitor
- 5.180 Clamp for the capacitor
- 5.300 Terminal box for electric motors  
with cast - iron frame
- 5.310 Gasket
- 5.320 Base of the terminal box

- 6.000 Back bearing shield
- 6.200 Spacing ring

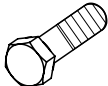
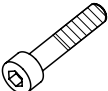
7.000 Fan - complete

8.000 Fan cover

5.113 5.182	DIN 555	
4.310 5.115 5.133 5.136	DIN 127	
4.320 5.111 5.132	DIN 46320	
1.600 5.320 6.400	DIN 933	
1.700 1.600	DIN 6912	
5.116; 5.151 5.131; 5.181 5.134; 6.500 5.135; 8.100	DIN 555	
2.000	DIN 6885	
1.500	DIN 625	
5.160	EN 50262	

# SERIES ESR

SINGLE-PHASE ELECTRIC MOTORS WITH RUNNING CAPACITORS

# SERIE ESR

EINPHASEN-ASYNCHRONMOTOREN MIT BETRIEBSKONDENSATOR

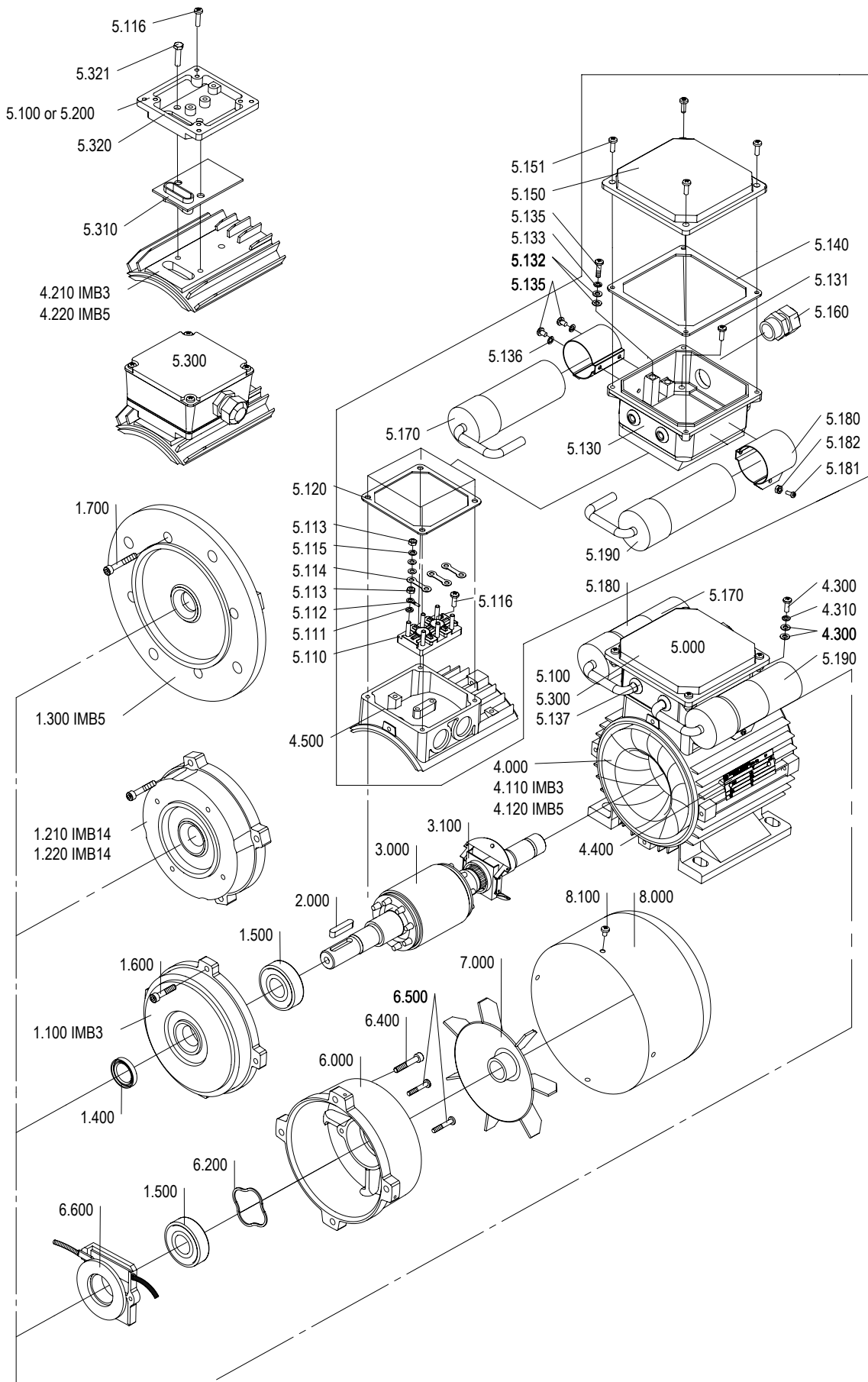

## SERIES ESR

SINGLE-PHASE ELECTRIC MOTORS WITH RUNNING CAPACITORS

## SERIE ESR

EINPHASEN-ASYNCHRONMOTOREN MIT BETRIEBSKONDENSATOR

- 1.100 Front bearing shield IMB3
- 1.100 Vorderes Lagerschild IMB3
- 1.210 Flange bearing shield IMB14 small
- 1.210 Flanschlagerschild IMB14 klein
- 1.220 Flange bearing shield IMB14 large
- 1.220 Flanschlagerschild IMB14 groß
- 1.300 Flange bearing shield IMB5
- 1.300 Flanschlagerschild IMB5
- 1.400 Radial oil seal IP55
- 1.400 Radialöldichtring für IP55
  
- 3.000 Rotor
- 3.000 Rotor
- 3.100 Centrifugal unit
- 3.100 Zentrifugaleinheit
  
- 4.000 Stator
- 4.000 Stator
- 4.110 Stator with aluminium frame IMB3
- 4.110 Stator mit Aluminiumkörper IMB3
- 4.120 Stator with aluminium frame IMB5
- 4.120 Stator mit Aluminiumkörper IMB5
- 4.210 Stator with cast - iron frame IMB3
- 4.210 Stator mit Gußkörper IMB3
- 4.220 Stator with cast - iron frame IMB5
- 4.220 Stator mit Gußkörper IMB5
- 4.400 Nameplate
- 4.400 Namensschild
- 4.500 Gasket
- 4.500 Dichtung
  
- 5.500 Aluminium terminal box-set
- 5.500 Aluminiumklemmenkasten - set
- 5.100 Aluminium terminal box and box cover
- 5.100 Aluminium-Klemmenkasten und Kastenabdeckung
- 5.110 Terminal board
- 5.110 Anschlussfeld
- 5.112 Terminal
- 5.112 Stiftleiter
- 5.114 Connection plate
- 5.114 Bindplatte
- 5.120 Gasket
- 5.120 Dichtung
- 5.130 Aluminium terminal box
- 5.130 Aluminium-Klemmenkasten
- 5.137 Gasket
- 5.137 Dichtung
- 5.140 Gasket
- 5.140 Dichtung
- 5.150 Terminal box cover
- 5.150 Klemmenkastendeckel
- 5.170 Running capacitor
- 5.170 Betriebskondensator
- 5.180 Clamp for the capacitor
- 5.180 Klemme für den Kondensator
- 5.190 Starting capacitor
- 5.190 Anlaufkondensator
- 5.300 Terminal box for electric motor with cast - iron frame
- 5.300 Anschlusskasten für Elektromotoren mit Gußkörper
- 5.310 Gasket
- 5.310 Dichtung
- 5.320 Base of the terminal box
- 5.320 Basis für Klemmenkasten
  
- 6.000 Rear bearing shield
- 6.000 Hinteres Lagerschild
- 6.200 Spacing ring
- 6.200 Sicherungsblech
  
- 7.000 Fan - set
- 7.000 Lüfter - Satz
  
- 8.000 Fan cover
- 8.000 Mantel

5.113 DIN 555  
5.182



4.310  
5.115 DIN 127  
5.133  
5.136



4.320  
5.111 DIN 46320  
5.132



1.600  
5.320 DIN 933  
6.400

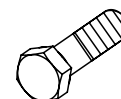

1.700 DIN 6912  
1.600

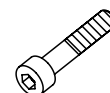

5.116; 5.151  
5.131; 5.181 DIN 555  
5.134; 6.500  
5.135; 8.100



2.000 DIN 6885



1.500 DIN 625



5.160 EN 50262



## HISTORY OF ELECTRIC MOTOR PLANT ELPROM TROYAN

### Over 75 years of ELPROM TROYAN



The town of Troyan in the 30s' of the 20th century



A view of the factory from the early 60s'



The view of the corporate building of Elprom Troyan from the early 80's

### How a factory becomes a legend – the history of ELPROM TROYAN

**ELPROM TROYAN**, the industrial pride and symbol of the city and the region, is reviving after the devastation and complete ruin the factory was brought to by the unscrupulous greed and managerial incompetence of the factory's previous owner - the notorious mass privatizer Nikolay Banev. Things are quite different since a years and a half ago when the bankrupt enterprise was bought by the new owners, the Mondeshki family. Serious investments, serious partnerships, company's own developments, international events, awards, large-scale development plans, and above all – modernization. Elprom Troyan is one of the few companies included in the Industry 4.0 Program (the fourth industrial revolution), whose aim is the so-called “smart plant”. All this was achieved despite the mistrust - it is a known fact that it is hard to build something after it has been devastated; despite common spread hatred; despite unfair competition blows; and despite the current difficulties of running an industrial production in our country, especially in a small town. Further below we present to you a retrospective article prepared by Elprom Troyan, which covers the development of the plant from the time of its creation until the present day.

### The Beginning – Industry 2.0

**Troyan** is one of the first cities in the country to start using electricity. At the end of 1926, with the support of Troyan Popular Bank Cooperative, local Nauka Library, and Slantse Power Supply Cooperative, a group of bright citizens of Troyan founded the Troyan Water Syndicate. After three years of hard work and an investment worth several million leva, the bulk of which was borrowed, the Syndicate fulfilled its mission. On the 11th of December 1929 the newly built power plant was commissioned and brought light to all of Troyan.

**In 1943**, a power transformer was manufactured in the small electrical workshop of Marin Staevski. The enthusiasts had only a tabletop drilling machine and a pair of scissors for sheet metal cutting. The situation with the materials was no better. Silicon sheet was in short supply. Winding conductors were made from hundreds of pieces. Nevertheless, the transformer was correctly calculated and manufactured, and it operated properly for five years, thus generating the idea of setting up an electrical industry in the city of Troyan.

**After World War Two**, in September of 1945, the Elkoop Electro-Technical Cooperative was founded at the initiative of Marin Staevski and the co-founders Tsocho Tsonevski, Tsonko Yakimov and Pavel Yovevski. In 1946, the Northern Bulgaria Electrification Department, after having supplied the required materials, ordered the first lot - 10 transformers with a power of 30 kW and voltages of 6000V/380V/ 220V.

## HISTORY OF ELECTRIC MOTOR PLANT ELPROM TROYAN



1982 Gold Mercury International Award giving ceremony in Sofia, Bulgaria

**Gold Mercury International Award for productive development and international cooperation.**



**Thus**, thanks to Troyan Water Syndicate and Elkoop Cooperative, Troyan was provided with electricity which became a prerequisite for the city's industrialization and massive industrial manufacturing (Industry 2.0) – a new beginning that forever changed the image of Troyan. Not surprisingly, we began by saying that our city was one of the first in the country to be electrified.

**In 1949**, the Electro-Technical Cooperative was transformed into a state owned enterprise as part of the electrical industry, and the Elprom (Troyan) factory was established, with its first Director being Marin Staevski. Shortly afterwards the electric motor factory was housed in a new building. In 1952, it ceased the production of transformers and moved on as a company focused on the production of collector, micro and asynchronous electric motors with low power of up to 2 kW and special electric machines combined with these motors.

**At about the same time** two of the founders, Tsocho Tsonovski and Tsonko Yakimov, were sent to visit Hungary to adopt special skills. The idea of setting up a group of technical experts emerged after their return. Thus, in 1951, the first technological group under the leadership of Yonko Hadzhiyski was created and the first technology cards, matrices, tools and devices were made. Despite the low qualification of the workers and the presence of only one dipl. engineer, the first group of technical experts managed to achieve good results. The silumin needed for castings was produced on site, and a special pot furnace was developed. The manufacturing of drilling machines required the adoption of new casting methods. The company introduced four-positional, consecutive dies for the static and rotor plates of the collector electric motors.

**The successes** of the new plant led to the undertaking of important new tasks. In 1956, the enterprise was commissioned for the first time with the execution of a state procurement – export of electric motors to Czechoslovakia, which was successfully completed without complaints. Chief Engineer Docho Velchevsky, Chief Constructor Eng. Dimitar Litchkov and Chief Technologist Eng. Stamen Ivanov had a major contribution to this first international event. Following the Czech order, a new Research and Development facility was created at the plant, providing conditions for the production of new items. A new electric laboratory was also developed under the management of Eng. Ivan Tsankov.

**For the Technological Department** the period after 1956 was characterized by the introduction of an assembly line production organization, and a project for the plant's first expansion had to be conceived. In 1959, the Technological Department led by a young engineer Dimitar Dobrev already numbered 50 people, and it became a competent and important unit in the organization of production. Assembly lines for the processing of hulls, shields and shafts were developed. The principle of assembly lines was transferred from the Mechanical Shop to the entire factory. Chains were made in the Press Shop; labor was reorganized in the Coil Section; assembly was prepared for conveyor work; and painting of the

## HISTORY OF ELECTRIC MOTOR PLANT ELPROM TROYAN



In the background is Mr. Marin Staeviski - the founder of ELPROM TROYAN

**Company of the Year 2018/2019**  
**“World Leader and Pioneer**  
**in industrial revolution 4.0”**



Special execution electric motor ELPROM TROYAN

finished products was carried out in a suspended conveyor, combined with a tunnel dryer with infrared rays.

**The presses** for semi-permanent molds for the casting of cast iron parts and the automatic line for the processing of housings are also worth mentioning as additional important technical solutions that were created at that time and involved the metallurgist Eng. Tsocho Tsvyatkov. Aggregates for the roller electric welding of dynamo sheets and the processing of rolls and conveyors for stators' impregnation were introduced at a later stage. An electric arc furnace was built for the smelting of cast iron waste.

**In 1961**, an independent Tools Department led by Peyo Radkov was established within the Technological Department, and a Metallurgical Department headed by Eng. Tsocho Tsvetkov was created. This was the department in charge of any major issue related to manufacturing. The pressurized pouring of machine rotors in two- and four-cradle molds was implemented. An electric arc furnace for the extraction of cast iron from waste was built and installed, and it generated large savings. An original method for casting in sand-clay forms molded under high pressure was developed and partially commissioned, and based on it, an automatic air-lever 200-tonne press was later constructed.

**In 1962**, a department for non-standard equipment was set up with the aim of developing a number of plant-specific machines and vehicles. In 1963, the first aggregate machines for bearing shields, the Schuler automatic presses in the Press Shop, and the pneumatic series for non-casing forming in the Foundry Shop were all put into operation. In the same year a national die casting conference was held at the plant, which demonstrated a non-casing forming with a factory own press designed by the engineer Tsocho Tsvetkov and the constructor Micho Radevski. At the conference, Eng. Tsvetkov presented a report on this innovative method.

**In the period 1960-1965**, Elprom (Troyan) entered into another stage of its development, with the plant increasing its production program by two and a half times. The goal was to move to a world standard level, regarding both quality of workmanship and labour productivity. The design and construction of a new assembly building started under the direct guidance of Engineer Dimitar Dobrev. The production process was set at the most modern basis available. Aggregate machines for the processing of bearing shields were introduced thanks to the assistance offered by the Aggregate and Special Machines Department of the Machine Cutting Plant (Sofia) headed by Engineer Yaroslav Genov. An automatic shaft line was also developed. The first automatic line in the Bulgarian machine building industry for processing of electric motors' hulls was built under the management of Eng. Veselin Grozdanov. Automatic presses for stator and rotor plates were delivered and commissioned, and in 1965 the manufacturing process shifted to operating with sheet metal roll, resulting in higher productivity. Following the introduction of a number of devices, the mechanical treatment and its quality were increased.

## HISTORY OF ELECTRIC MOTOR PLANT ELPROM TROYAN



Vision of the catalogue of Elprom Troyan for the year 2019



Vision of the catalogue of Elprom Troyan for the year 2017

In 1968, a Scientific Labour Organization Department led by DochoSheytanov was created in Elprom (Troyan). Ivanka Miteva, Stefan Popov, Gergina Datsova and Tsocho Tsonovski also worked in the department, but a year later it had a new manager - Marin Kovachev. Two new units were established in 1970 within the same department: Organization and Management Systems (OMS) and Production and Management Comprehensive Automation (PMCA). The same year Dimitar Geneshki was appointed as head of department and began cooperating with Grün Hein - an electric motor factory in what was then German Democratic Republic (GDR). In 1977, National Production Association "Automation" and State Enterprise Elprom entered into an agreement for the development and commissioning of OMS tasks based on the Proprietary Method License that was purchased from a French company.

### Industry 3.0 - the era of automation and digitization

The third expansion took place in 1966-1967. The new halls accommodated mechanical, press, coil, assembly, painting and packaging workshops. The main building of the old production facility was made available for the production of tools and non-standard equipment based on four-position segment dies. Large-scale industrial products, model equipment and a variety of non-standard devices were introduced there, not only for the plant but for other related enterprises in the country also.

In 1981, OMS was equipped with a multi-panel system for the preparation of magnetic tape data type МСПДМЛ/Е/ 9003, and after a special room was designated for this purpose, the new operators began attending a training course. The system was approved on the 17th of June 1981 - the date on which the first electronic machine was set up both in the plant and the city itself. A second minicomputer calculating system was delivered on the 1st of March 1984, and in 1988 there were three of them.

This period was characterized by the emphasis which Elprom (Troyan) placed on the production of asynchronous electric motors and their operational machines. Certain modifications such as two-speed motors, single-phase motors with a start-up capacitor, and other special purpose motors were also developed. The production range of the plant grew and the manufacturing of micro electric motors and machines had to be moved to a separate enterprise. The result of all of this being the incorporation of a new entity called Elprom (Lovech). In a similar fashion, Elprom (Troyan) launched two more industrial sites - Elprom (Teteven) and Elprom (Etropole) – which were subsequently developed and strengthened.

**Elprom (Troyan) Electric Motor Factory** was focused on large-scale production of asynchronous electric motors with dimensions 0, I, II, III and power up to 4 kw, as well as on the manufacturing of electric machines such as electric emeries, fans, pumps, etc. The plant fully met the country's need of

## HISTORY OF ELECTRIC MOTOR PLANT ELPROM TROYAN



ELPROM TROYAN presenting our innovation SDM 30 First "smart electric motor" in the world



ELPROM TROYAN with a gold medal for Innovation in the International Technical Fair in Plovdiv 2017



Mr. Hristofor Staevski - son of Marin Staevski the founder of ELPROM TROYAN poses with the gold medal

such electric motors. It delivered its products to more than 80 machine-building companies and trade organizations. The rapid pace of its development imposed the construction of workshops on the territory of Troyan Municipality. The first branches were located in the villages of Golyama Zhelyazna and Staro Selo, where parts of the production of coils for the laundry machine's electric motors was transferred, along with the production of coloured castings and the process of bakelite pressing. Modern shops were built there in a few years, and after their commissioning in 1983, they started manufacturing electric motors for water pumps and laundry machines (village of Golyama Zhelyazna), as well as various consumer goods (village of Staro Selo). In 1978, a new large subsidiary of the factory began its operations. A brand new foundry for non-casing forming was put into operation in the village of Oreshak – a workshop equipped with modern semi-automatic lines for stamping, packaging and heat treatment of silicon fresheet metal.

**In its decades of development** the factory brand Elprom (Troyan) proved itself and took a worthy place on the international market. The plant became export oriented. The Bulgarian foreign trade company Electroimpex sold the electric motors produced by the factory in all socialist countries: USSR, GDR, Czechoslovakia, Poland, Hungary, Cuba, Albania, but most of the exports were shipped to industrialized capitalist countries like the Federal Republic of Germany, France, Italy, Belgium, Netherlands, Greece, Turkey, as well as for developing African, Asian and some Latin American countries. The extensive product range of the plant, the high reliability and superior quality of its engines were gaining more and more customers on the international market. The progress of Elprom (Troyan) seemed very promising and profitable for our economy. By 1982 the single series of electric motors designed and commissioned back in 1959 had already fulfilled its purpose. The plant now offered electric motors from the series 4A080Д, 90Д, 100Д, П2Д, 4Е0КА80Д, 90Д и 4Е0КАД-90Д, which featured improved torque and performance, lightweight structure, contemporary design and increased reliability. The 1981 implementation and commissioning in serial production of high-speed drives that were meant for assembly into digital and software operated metal cutting machines with a torque of 7 up to 47 Nm was a special pride. Technical progress would be unthinkable without the production of high-speed drives, for the real world experience had confirmed the advantages of digital and software operated metal cutting machines. In that period the plant manufactured high-speed drives which were exclusively exported to USSR, but the future production growth of this highly efficient item created the right conditions for export to other countries.

**Over many years of operation** the plant has welcomed and trained a lot of specialists. The Production Training Centre for Education and Retraining of Personnel had constantly been developing and improving its activity. The plant has been awarded the Red Flag Labor Order, and in recent years it has received seven gold and two silver medals at the Plovdiv International Fair. In 1978, the personnel received a gold medal for the implementation and manufacturing of a family

## HISTORY OF ELECTRIC MOTOR PLANT ELPROM TROYAN



"Mr. Mondeshki with His Excellency Herbert Salber, Ambassador of the Federal Republic of Germany and the Vice president of AHK Mr. Roman Herp at the "Company of the year 2017/2018" award giving ceremony



"Prize of the German Economy 2017" received by ELPROM TROYAN

of electric motors from series 4A0. The State Committee for Scientific and Technical Progress endorsed the highest quality category by assigning the sign "K" to products 4A080Д, 90Д, 100Д, 112Д, 4E0KA80Д и 90Д. The plant took great care in improving the working conditions. Problems related to safety, work hygiene and the elimination of heavy and unattractive work were successfully resolved by increasing the level of automation and modernization of the production processes. In each workshop the number of employees working in overall improved labour conditions increased every year. The staff's housing issues were successfully handled in those years.

**In honour of the plant's anniversary**, it completed the final stage of the modernization, reconstruction and expansion of the main funds, the renovation of output with the already adopted new series 4A0 for electric motors, the implementation of brand new technologies in the mechanical processing of automatic lines' hulls, bearing shield and shaft-rotor, and new casting technology. An upgrade of foundry workshop №70 was under way, and a separate plant for high-speed drives was being designed. A project for the modernization and reconstruction of a separate unit for the production of tools and non-standard equipment was drafted and approved, which had to twofold increase the productivity of a person from the industrial and manufacturing staff.

**As a part of the labour intellectualization program** and the introduction of electronic computing machines, in 1982 the plant was equipped with a Computer Centre. Its construction was needed so as to improve the management of the production cycle and the real-time financial and accounting transactions. The Computer Centre used subsystems for commodity and material values, labour and wages, material and technical supplies, warehouse management and regulatory reference base. A subsystem for the operational management of the production cycle was also introduced. In 1982, Elprom (Troyan) received the prestigious international Golden Mercury Award for production development and international co-operation.

**The plant's non-profit organizations** covered all workers and employees. Many youngsters took part in the amateur art and photo club. During the long period of massive sports activities, the factory has many times won district and national awards. The only worker's circus troupe in the country was constantly performing. Many awards were won by the plant's dance group, string and pop band, and vocal group.

**On the 2nd of October 1987**, trade union activists from Elprom Electric Motor Plant (Troyan) put in a sealed capsule a message to the next generations: "Love your factory and your team; strive for achievements greater than ours; and praise forever the name of the factory among your followers!" The optimism of the generation who wrote the covenant would be left unshared, for the plant was about to be destroyed. After the political changes in 1989, the plant was included in the mass privatization program and sold. In the same year of 1989, it was renamed Elma AD, but everyone still called it

## HISTORY OF ELECTRIC MOTOR PLANT ELPROM TROYAN



Mr. Mladen Mondeshki - owner and manager of the company on the cover of Bulgarian Business review magazine



"Company of the year 2017" award giving ceremony



The owner of the company, Mr. Mondeshki and Ms. Petkova - Marketing and Innovation manager, receiving the award "Company of the year 2017" accompanied by Mr. Borisov, the Vice-minister of Economy of Bulgaria.

Elprom and the people working there were simply "elpromtsi". What came next was the destruction performed by the private owner Nikolay Banev

**Today Elprom Troyan is a symbol of Industry 4.0, and it has created the first "smart electric motor" in the world.**

**WHAT DOES IT MEAN** to be the creator of the world's first "smart electric motor" and to turn Troyan into a Symbol of Industry 4.0. That is Elprom Troyan. Also, why do we say that the plant glorifies Troyan now, when we celebrated the 150th anniversary of its proclamation as a city? Because, as even the children know, "elprom" means "electrical industry", just as "vinprom" means "wine industry". And the two Troyan plants carrying these names - Elprom Troyan and Vinprom Troyan - have earned many medals and awards, and are among the brightest symbols of Troyan (Vinprom Troyan has 28 gold and silver medals, and Elprom Troyan - 11 gold medals).

In 2016, the factory was bought by the Mondeshki Family. The support of all Elprom employees was a key element in the recovery plans. The sons of the founder, Marin Staevski, were actively involved and shared the joy of the plant's rebirth - these are Nayden and Hristofor Staevski, who have worked here all their lives. Workers and employees actively participated in the restoration process aimed at making Elprom Troyan - the pride of the citizens of Troyan and Troyan itself - glamorous again.

**A major overhaul of the production** buildings and premises, administrative facilities and adjacent areas was initiated, with the scheduled investments exceeding 5 million leva. Elprom-Troyan hired some 120 people, including 10 scholars who study engineering and have signed employment contracts with the plant. The factory's Research and Development Institute was restored. New standards on energy efficiency were introduced in compliance with European Regulation 640/09, and the company's output and operations meet the stringent requirements of ISO 9001:2015, ISO 14001:2015 and IEC 17025.

**On the 27th of September 2017**, Elprom Troyan presented the world's first "smart electric motor" and was awarded golden medal for innovations and Crystal Tetrahedron for the fair exposition's best design at the 73rd International Technical Fair in Plovdiv. This is the 11th golden medal earned by Elprom Troyan. In November 2017, Elprom Troyan stated its ambition to be an industry leader at the first International Business Forum organized by the Bulgarian Innovations Confederation. The presentation was focused on the digital smart laboratory (Smart Digital Monitoring) developed by us. SDM is mandatory equipment for the special motors of Elprom Troyan, and it monitors all 16 important parameters of the working electric motor in both real time and in the electronic memory, the so-called Cloud, which enables each user to use the factory's software algorithm. This new high-tech device is assembled with electric motors and is widely applied in the heavy conditions of the chemical, oil, mining,

## HISTORY OF ELECTRIC MOTOR PLANT ELPROM TROYAN



"Company of the Year 2018/2019 award in the category "Industry" as "World leader and pioneer in Industry 4.0"



74th International Technical fair in Plovdiv



The renovated administrative building of ELPROM TROYAN

military, automotive and other industries. All this resulted in Elprom Troyan being invited to become a member of the Innovations Confederation. The plant is also a member of the Managing Board of Industry 4.0 Cluster, where selected innovative enterprises and proven industry leaders outline the future development of technology on an international scale.

**Whereas in the 1980s** Elprom Troyan became an Industry 3.0 leader in Central and Eastern Europe (the third industrial revolution started in 1969), in which period it received 5 golden medals from international technical fairs, nowadays Elprom Troyan is among the world leaders in Industry 4.0. The successes of Elprom Troyan were also reported by the respectable British economic daily Financial Times in an issue dated 11th of January 2018. The information about the Troyan enterprise was published on the pages dedicated to Bulgaria's assumption of the Presidency of the European Union Council. This is the first international presentation of the sensation which is the world's first "smart electric motor" – a piece of news that has reached more than 600 000 people around the globe.

**On the 25th of January 2018**, His Excellency Herbert Salber, Ambassador of the Federal Republic of Germany in Bulgaria awarded Elprom Troyan with the German economy prize in section "Innovations", in the presence of the President of the Republic of Bulgaria Roumen Radev. This was also a recognition of Elprom Troyan's leadership in Industry 4.0. Other nominees for this prestigious award included: Lidl Bulgaria, EVN Bulgaria, Bayer Bulgaria, Siemens and Bulpros Consulting. The prize went to Elprom Troyan, which speaks of the plant's leading position following its creation of the world's first "smart electric motor".

**The products of Elprom Troyan** have always been highly appreciated due to their uncompromising quality. While attending the specialized exhibition in Ekaterinburg, Russia, held in the period 20-22nd of March 2018 the plant was awarded a diploma, and on the 19th of April 2018 Elprom Troyan was declared "Company of the Year" for 2017 in category "Sustainable Development, Competitiveness and Innovation", alongside with VP Brands International (formerly known as Vinprom Peshtera) in category "Successful Management", Fibank in category "Banks", Minstroy Holding in category "Total Contribution to the Mining Industry", Philip Morris Bulgaria in category "Fast Moving Consumer Goods", Nova Television in category "Media and Television", and M Tel (now rebranded as A1) in category "Society Care and Customer Approach". In the period 23-27th of April 2018, Elprom Troyan made an impressive presentation of its innovative product at the biggest international fair - Hannover Messe in Germany - held under the title "Industry 4.0".

**Thanks to its technological innovations** the plant has successfully proven that it deserves a place among the biggest names in the industry.

**Representatives** of Elprom Troyan took part in the most important economic and political events in our country - the

## HISTORY OF ELECTRIC MOTOR PLANT ELPROM TROYAN



The future for ELPROM TROYAN is already here

**Company of the Year 2018/2019**  
**“World Leader and Pioneer**  
**in industrial revolution 4.0”**

Vienna Economic Forum and the Forum on Clean Technologies and Circular Economy held on the 18th of May 2018 as part of the European leaders' summit - and they also attended the 16 + 1 Forum of the Leaders of Central and Eastern Europe and China held on the 7th of July 2018.

**So, in a short period** of time the new owner of the plant managed to achieve several major goals: the company returned on the international markets; it was recognized for its innovations and was assigned to the group of so called “smart factories” which has changed the manufacturing philosophy and the life of people. It is imperative to point out that the achievements of Elprom Troyan are crucial to the country and beneficial to the city of Troyan itself.

**At the 74-th International Technical Fair in Plovdiv** held in the period 24-29.09.2018, Elprom Troyan presented its new developments for protection and monitoring of the brake systems of the electric motors. The innovations of Elprom Troyan are awarded with 4 Gold Medals. Thus, within just 2 years, the plant was awarded with 5 gold medals. The impressive design of the stand is also well appreciated and Elprom Troyan receives the prestigious award for Design - Crystal Tetrahedron - again for a second consecutive year.

**On 21-st April 2019**, for a second year in a row, “Elprom Troyan” is awarded with the prestigious Prize “Company of the Year” in category “Industry” as a “World leader and pioneer in industry 4.0

**Electric motor plant Elprom Troyan** is a full member of many chambers of commerce and branch organizations. The factory is a member of the French - Bulgarian Chamber of Commerce and Industry, German - Bulgarian Chamber of Industry and Commerce, Bulgarian Branch Chamber - Machinebuilding, Bulgarian Association of Electrical and Electronic Engineering, Cluster Industry 4.0, Bulgarian Confederation of Innovations, Defense Industry Club.

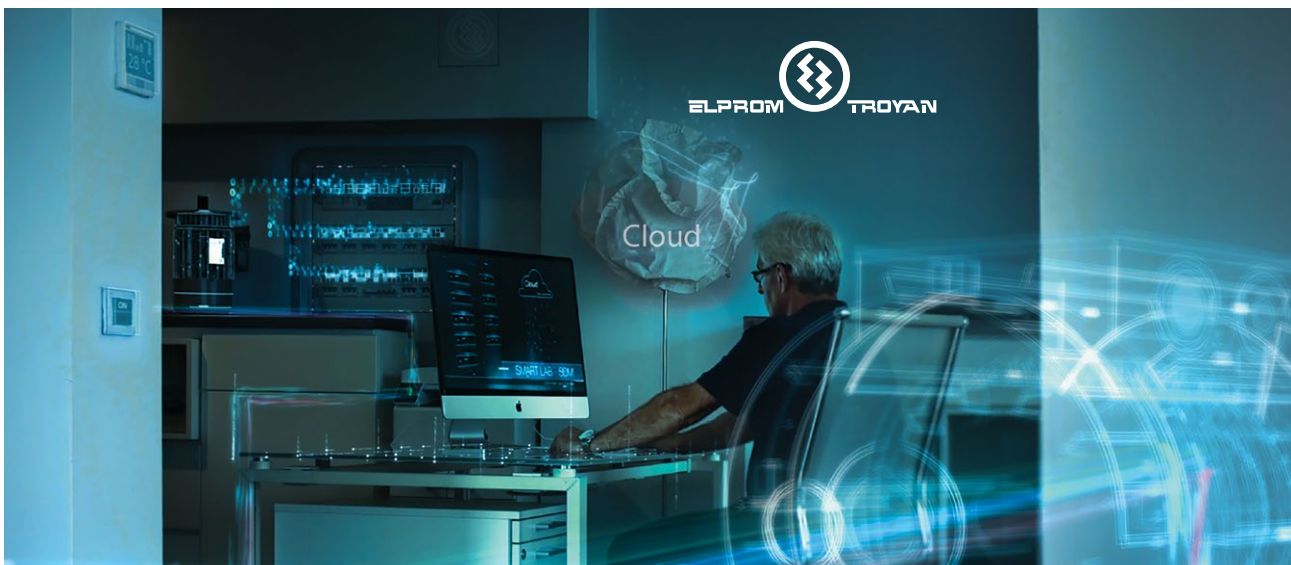

ELPROM TROYAN presents the company's vision for the next 100 years

**TUV NORD**

## CERTIFICATE

Management system as per  
**BDS EN ISO 9001 : 2015**

In accordance with the procedures of the Certification Body at TÜV NORD Bulgaria EOOD, it is hereby certified that

**EZ ELPROM TROYAN EOOD**  
1, Acad. A. Bolevski Str.  
5600 Troyan  
Bulgaria



applies a management system in line with the above standard for the following scope

**Development, production, testing and service of single phase, three phase electric motors, and electric motors with built-in electromagnetic brake, (for) telphers, water pumps and systematic management decisions, diagnostics and transmission equipment.**

Certificate Registration No. 32 100 170046	Valid from 2017-08-07
Audit Report No. 3217 0422	Valid until 2020-08-06
	Initial certification 2017

*[Signature]*  
MS Certification Body at  
TÜV NORD Bulgaria EOOD

Plovdiv, 2017-08-07

TÜV NORD Bulgaria EOOD    13, Naiden Gerov str.    4000 Plovdiv    www.tuev-nord.bg



**TUV NORD**

## ZERTIFIKAT

für das Managementsystem nach  
**BDS EN ISO 9001 : 2015**

Der Nachweis der regelwerkskonformen Anwendung wurde erbracht und wird gemäß der Verfahren der Zertifizierungsstelle der TÜV NORD Bulgarien EOOD bescheinigt für

**EZ ELPROM TROYAN EOOD**  
Akad. A. Bolevski Str. 1  
5600 Troyan  
Bulgarien



Geltungsbereich

**Entwicklung, Produktion, Prüfung und Wartung von einphasigen, dreiphasigen Elektromotoren und Elektromotoren mit eingebauter Bremse, Hubwerken, Wasserpumpen und Systemlösungen zur Führung, Diagnostik und Übertragungstechnik.**

Zertifikat-Registrier-Nr. 32 100 170046	Gültig von 2017-08-07
Auditbericht-Nr. 3217 0422	Gültig bis 2020-08-06
	Erstzertifizierung 2017

*[Signature]*  
Zertifizierungsstelle für Managementsysteme  
der TÜV NORD Bulgarien EOOD

Plovdiv, 2017-08-07

TÜV NORD Bulgarien EOOD    Naiden Gerov Str. 13    4000 Plovdiv    www.tuev-nord.bg



**TUV NORD**

## CERTIFICATE

Management system as per  
**BDS EN ISO 14001 : 2015**

In accordance with the procedures of the Certification Body at TÜV NORD Bulgaria EOOD, it is hereby certified that

**EZ ELPROM TROYAN EOOD**  
1, Acad. A. Bolevski Str.  
5600 Troyan  
Bulgaria



applies a management system in line with the above standard for the following scope

**Development, production, testing and service of single phase, three phase electric motors, and electric motors with built-in electromagnetic brake, (for) telphers, water pumps and systematic management decisions, diagnostics and transmission equipment.**

Certificate Registration No. 32 104 170046	Valid from 2017-08-07
Audit Report No. 3217 0423	Valid until 2020-08-06
	Initial certification 2017

*[Signature]*  
MS Certification Body at  
TÜV NORD Bulgaria EOOD

Plovdiv, 2017-08-07

TÜV NORD Bulgaria EOOD    13, Naiden Gerov str.    4000 Plovdiv    www.tuev-nord.bg



**TUV NORD**

## ZERTIFIKAT

für das Managementsystem nach  
**BDS EN ISO 14001 : 2015**

Der Nachweis der regelwerkskonformen Anwendung wurde erbracht und wird gemäß der Verfahren der Zertifizierungsstelle der TÜV NORD Bulgarien EOOD bescheinigt für

**EZ ELPROM TROYAN EOOD**  
Akad. A. Bolevski Str. 1  
5600 Troyan  
Bulgarien



Geltungsbereich

**Entwicklung, Produktion, Prüfung und Wartung von einphasigen, dreiphasigen Elektromotoren und Elektromotoren mit eingebauter Bremse, Hubwerken, Wasserpumpen und Systemlösungen zur Führung, Diagnostik und Übertragungstechnik.**

Zertifikat-Registrier-Nr. 32 104 170046	Gültig von 2017-08-07
Auditbericht-Nr. 3217 0423	Gültig bis 2020-08-06
	Erstzertifizierung 2017

*[Signature]*  
Zertifizierungsstelle für Managementsysteme  
der TÜV NORD Bulgarien EOOD

Plovdiv, 2017-08-07

TÜV NORD Bulgarien EOOD    Naiden Gerov Str. 13    4000 Plovdiv    www.tuev-nord.bg



## SMART digital monitoring

SDM 30

Smart device with numerous awards and international prizes for INNOVATION

With us, the future begins today. You can now have your own highly technological digital laboratory at your disposal. It combines the knowledge and experience of several generations of engineers, and is inspired by the pioneers of machine engineering in Bulgaria. This is ELPROM Troyan – new and modernized, but connected to its over 70 years old history, using the same buildings and land, that are known as the name of machine manufacturing in Bulgaria that is ELPROM Troyan.

Mobile technological laboratory designed by ELPROM Troyan, that we called SMART Digital Monitoring – SDM is your personal lab. It can be attached to any electric motor, and can be used to monitor in real time all the basic characteristics of the working motor, with all the precision of a fully equipped dedicated testing laboratory. The implementation of our SDM module – Your personal laboratory, created by us for your convenience, will allow you to be in charge of your electric motors. No matter where you are and how

far your motors are from You, all working parameters of every unit will be at your disposal. The SDM laboratory will help prevent errors and dysfunction throughout the whole lifecycle of the electric motor from the moment You install it by offering continuous monitoring of all working parameters, “on the spot” diagnostics of potential problems, that could lead to a technical or mechanical problems, keeping track of the service cycles of electric motors depending on the ambient environment and workload, as well as individual analysis of all the motor characteristics, derived from all collected information. SDM Laboratory will use all that information to provide specific recommendations for the exploitation of every electric motor. SDM30 personal laboratory will also monitor and manage the safety and energy efficiency levels of the motors.

Thanks to ELPROM Troyan the future is here and now! Welcome to the Machine building of tomorrow!

First “Smart electric motor in the World 2018”, awarded the Prize of german Economy

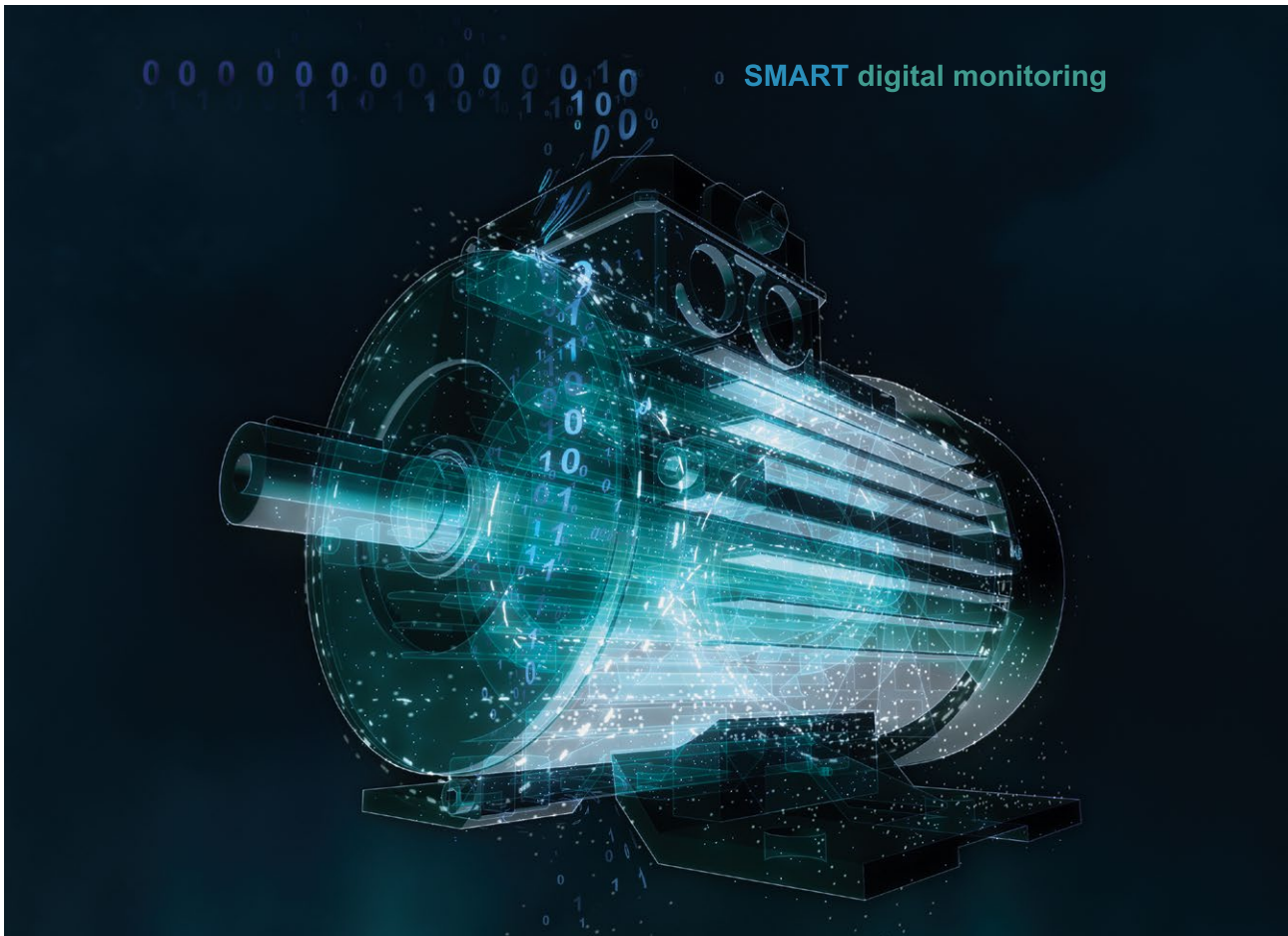

## Basic functional capabilities of the SDM Technology

1. Control and protection of the electric motor
  - 1.1 Monitoring of the alignment of the Phases
  - 1.2 Monitoring for disconnection of any of the Phases
  - 1.3 Monitoring of the current
  - 1.4 Monitoring of the current in all Phases
  - 1.5 Monitoring the temperature of the electric motor with the installed PTC protection
2. Measurement and visualization of all parameters in real time.
  - 2.1 Measurement of all three phases
  - 2.2 Measurement of the current in all three phases\* Maximum current up to 30A ( 3 X 10A). The starting current may exceed this value.
  - 2.3 Measurement of active power
  - 2.4 Measurement of reactive power
  - 2.5 Measurement and monitoring of  $\cos\varphi$
  - 2.6 Measurement of the temperature of the frame of the electric motor
  - 2.7 Measurement and monitoring of frequency harmonics

Accuracy of the measurements  $\leq 1\%$  with ambient temperature between  $-24\text{C}$  and  $+60\text{C}$
3. Measurement, storing and visualizing the work process.
  - 3.1 Work- hours of the electric motor
  - 3.2 Power consumption - kWh
  - 3.3 Working minimum and maximum values of:
    - Voltage
    - Electric current
    - Temperature
4. Monitoring and visualization of all available information in real time.
5. All the available information is saved to a server or cloud technology through RS 485 industrial communication bus, for the purpose of storing and additional analysis.

SDM 30 is a digital monitoring device for analysis, control and protection with real-time information display of electric motor characteristics and lifecycle working information. This gives you the opportunity to make the right decisions regarding the exploitation, servicing and maintenance of the motor. This will give you the pleasure and benefits of owning your very own measuring and analysis laboratory –

SMART Digital Monitoring.

SDM 30 is a device that measures all fundamental characteristics of the electric motor. The amount of values monitored by the device at any time is at least 16. You can also review all the analytic data about the lifecycle of the motor since it was installed. Your SMART Digital Monitoring device will provide recommendations, diagnostics and error correction, based on complex algorithms and the collected information.

